

# SMART OFFICE AUTOMATION FOR ENERG SAVING USING IoT



By  
**Shaista Rasool Cheema**

**Department of Electronics  
Quaid-i-Azam University  
Islamabad Pakistan**

**2019**

# SMART OFFICE AUTOMATION FOR ENERG SAVING USING IoT



By  
Shaista Rasool Cheema

Department of Electronics  
Quaid-i-Azam University Islamabad, Pakistan

*Bachelor of Sciences*

July, 2019

# **SMART OFFICE AUTOMATION FOR ENERG SAVING USING IoT**

**By**

**Shaista Rasool Cheema**

*A Thesis Submitted in Partial Fulfillment of the Requirement  
for the Degree of Bachelor of Science in Electronics*

**Department of Electronics  
Quaid-i-Azam University  
Islamabad**

A thesis titled as “IoT connected smart office applications” is submitted by Shaista in partial fulfillment of the requirements for the Degree Bachelor of Science, has been approved by the following faculty members

Advisor

(Professor Hasan Mahmood)

Department of Electronics

Quaid-i-Azam University

Islamabad

Chairman

(Professor Syed Aqeel Abbas Bukhari)

Department of Electronics

Quaid-i-Azam University

Islamabad



O ALLAH, INCREASE US  
IN KNOWLEDGE!

*(SurahTaha-114)*

***Dedicated to my beloved parents without their support, love, care and encouragement, I would not be able to complete this task.***

## Acknowledgments

I would like to acknowledge and pay my gratitude from the core of my heart with due respect to my supervisor Dr. Hasan Mahmood whose continuous encouragement, suggestions, advice, politeness have made it possible for me to accomplish this project.

There were times when i lost hope to be able to complete my project due to lack of knowledge and complexity that increased by time as we got indulged more in my project, but the person who made me believe that we are the one who can do this job by saying,

“Any one of you is surely going to be failed.”

That joke of him always gave me the hope that i can prove that I am not one of those who is going to fail. After every meeting with Dr. Hassan i felt more determined and more confident towards our project due to his honest and diligent counseling. I would like to thank all of my faculty members especially Dr. Naeem Bhatti and staff of electronics department for their support and encouragement during this time period.

My special thanks goes to my mother, who made me able to reach at this stage of life to be able to do something different and innovative. Thanks to my father for his endless love, care and financial support without which it was not possible. I am very thankful to my siblings for believing that we are not going to complete this project, but we were always aware of that deep inside you believe in me more than anybody else but all of your words are just to boost me up.

**Shaista Rasool Cheema**  
**July 2019**

## **Abstract**

Due to day-by-day increase in the cost of energy, it has become a need of every individual to efficiently consume energy. This project presents a detailed description of how to save and better utilize energy and make tasks easier by using Internet of things (IoT). All the office appliances are automated to avoid waste of power due to human behavior. If a person is not present in a room, all appliances such as fan, air conditioner and heater should be turned off to save energy. In this thesis, if a person enters in a room, the lights turns on automatically by use of IoT paradigm. In the presence of a person in a room, the air conditioner or heater must be managed automatically. The light and exhaust fan of washroom is turned on automatically when a person is using the facility, and light is immediately switched off when not in use. The exhaust fan of the washroom remains on for two minutes after the person exits and then it turns off automatically. In order to keep the record of all the power consumption at a facility, a current sensor is used that measures current consumption and a log is created in the database. The user can access the usage statistics through a web application. In order to keep user aware of the presence of harmful gases or smoke in case of a fire, a toxic gas sensor is also used that is connected to an alarm. The users are notified and are kept aware, through a web application, while the logs from sensor data are created in a database. A web application is also used to control appliances by analyzing data from different type of sensors while keeping in view the user settings.



# Contents

Acknowledgments.....	i
Abstract.....	ii
Chapter 1.....	1
Introduction .....	1
1.1 Internet of Things (IoT).....	1
1.2 Background.....	2
1.3 Applications .....	2
1.3.1 Transportation:.....	2
1.3.2 Environmental monitoring: .....	3
1.3.3 Medical and health care: .....	3
1.3.4 Smart city:.....	3
1.3.5 Energy engagement:.....	3
1.3.6 Wearable’s devices:.....	3
1.3.7 Connected cars: .....	3
1.3.8 Smart office automation: .....	4
1.4 Issues of IoT.....	4
1.4.1 Connectivity:.....	4
1.4.2 Security: .....	4
1.4.3 Compatibility: .....	4
Chapter 2.....	5
Design and Working.....	5
2.1 Design .....	5
2.2 Working .....	6

Chapter 3.....	7
Components.....	7
3.1 DHT 11.....	7
3.2 MQ 9.....	9
3.3 Current Sensor acs712 .....	11
3.4 Infrared sensor (motion sensor) .....	12
Chapter 4.....	15
Microcontroller .....	15
4.1 Raspberry Pi.....	15
4.1.1 OS (Operating system) of Raspberry Pi: .....	16
4.2 NodeMCU ESP E12 .....	17
Chapter 5.....	19
Database .....	19
5.1 Introduction.....	19
5.2 Goals .....	19
5.3 Components results on database .....	19
Chapter 6.....	22
MQTT protocol.....	22
6.1 MQTT introduction.....	22
6.2 MQTT architecture for publish-subscribe .....	22
6.3 Ideal for limited networks .....	22
6.4 Quality of service of MQTT.....	23
Chapter 7.....	24
Web Application.....	24
7.1 Background.....	24

7.2 Web application interface .....	24
Chapter 8.....	26
Implementation .....	26
Chapter 9.....	27
Conclusion.....	27

# Chapter 1

## Introduction

Now a days, energy saving is one of the most important issues because energy is being expensive. Often people forget to turn off appliances when these appliances are not in use. In this project, office appliances are automated to avoid wastage of energy due to carelessness of human beings. Each of office appliances is automated by use of a network of microcontrollers and sensors. Lights, Air conditioner or heater and water pump are automatically controlled by the use of IoT to save power.

### 1.1 Internet of Things (IoT)

IoT is a platform that connects people and devices through Internet. Now a day's IoT is being popular rapidly with the technological evolution the principal purpose of IoT is to govern and control gadgets around with an extra highbrow and correct manner and to improve the human life style with cost effective living including safety, security and compatibility.

One of the most capable platforms used in IoT is Raspberry Pi, which is a mini computer that makes complex and heavy networks easier by using minimal extras. Raspberry Pi provides a Linux server in a tiny package with a very low cost. All different microcontrollers and sensors may be without problems related to the Raspberry Pi through any access point.

In many IoT applications, the Smart office plays a vital role in building a smart town. Smart office may be used for remote monitoring and controlling electric office equipment in the office using smart and intelligent bodily infrastructure. In "Smart office" the word "smart" means context aware, this will be made by the use of Information and Communication Technology (ICT) and IoT and how IoT can be used for smart office automation using microcontrollers, Raspberry Pi, NodeMCU (8266) boards and web applications.

## 1.2 Background

A developing paradigm in computing is the Internet of Things. In IoT items or devices are connected to the Internet that could collect, process, and share information. These also are known as related devices or smart devices.



**Fig. 1.2 Smart office internets of Things**

Most people already carry around an IoT tool with them such a smart telephone. Now many other linked gadgets have become available to customers, businesses, and towns, wearable gadgets voice-activated speakers that function as digital assistant, smart thermostats that discover ways to keep private office comfortable even as additionally saving strength, smart streetlights that routinely brighten or dim based on what number of pedestrians or vehicles are close by, etc.

## 1.3 Applications

### 1.3.1 Transportation:

Our lives run on transportation. IoT can play important role in transportation for our ease. Incorporation of IoT in transportation may be as small scale (an automobile to

individual communicate e.g. next station is Faizabad) and as large scale as monitoring delivery logistics of a global organization.

### **1.3.2 Environmental monitoring:**

IoT can be used in environmental monitoring. Sensors are used to assist environmental protection by monitoring atmosphere situations e.g. monitoring movement of wild life and their habits.

### **1.3.3 Medical and health care:**

IoT gadgets may be used to enable fitness monitoring and emergency notification machine e.g. smart beds that can be detected when they're occupied and whilst affected person is making an attempt to arise.

### **1.3.4 Smart city:**

IoT technology can be utilized in water distribution and traffic management to waste management and environmental tracking. It attempts to put off the pain and problems in city existence.

### **1.3.5 Energy engagement:**

IoT may be used in smart grids to gather statistics routinely and analyze the ratio of strength consumers and suppliers for improving performance. Smart Grids may also be capable of come across resources of strength at character household levels like sun panel and many others.

### **1.3.6 Wearable's devices:**

IoT can be used in wearable devices. Sensors and Software are used in Wearable devices, which fetch data about its user. These wearable devices keep a track of health and fitness of its user. For example, smart watch, fit bit charger etc.

### **1.3.7 Connected cars:**

IoT is playing an important role in connected automobile technology. It is helping to avoid the accidents by vehicle to vehicle communication, cameras and radars are used for this purpose and by using IoT we can check vacant parking.

### **1.3.8 Smart office automation:**

In IoT our major focus is office automation. It will be beneficial for security of Office, saving energy, saving of time and not a single task will be missed in busy life. It is reliable and easy to control. Office automation is for comfort and peace of mind. The whole system consists of sensors, microcontrollers, networking hardware/chipsets, microprocessors, embedded systems and the Internet. Constant monitoring and ordinary notifications, it additionally helps with office maintenance.

## **1.4 Issues of IoT**

IoT is a huge platform and there are a lot of technological challenges of great importance. IoT has issues due to day by day increasing technology, a few of which are discussed here.

### **1.4.1 Connectivity:**

Connecting multiple devices to some common node is not going to be an easy task. As far as IoT has not prevailed the market yet, but it is going to be greatest demand ever, soon in a few years. So the devices would increase tremendously and to incorporate a centralized system for different nodes would be a challenge. But these challenges can be met by emerging IoT technologies. Need connectivity 24/7 for IoT that has larger heterogeneous of devices

### **1.4.2 Security:**

Security is one of the most important concerns of IoT because hacking is too common in today's world. So many major steps in higher security measurements are required to make network more secure and build confidence in the end users regarding to safety of their personal information.

### **1.4.3 Compatibility:**

IoT is growing in many different areas and some of technologies are being used today might be obsolete in next few years. It might create problems to deploy compatible devices with change in technology over years.

## Chapter 2

### Design and Working

#### 2.1 Design

The system is made up of sensors, microcontrollers, networking hardware/chipsets, microprocessors, embedded systems and the Internet. The goal is to provide connectivity and data mining capabilities that uses Internet and online server to process data and make intelligent decisions for the end users. The principal of the system is based on artificial intelligence algorithm, which performs all the computations and communicates with distributed processing units installed at various locations in the buildings. The choice of sensor plays a crucial role in the performance of system. In addition to quality of the sensors, the calibration is carefully managed by the software in order to reduce errors. The Wi-Fi technologies are used for easy integration with the existing hand held devices and computers. In order to make the system well grounded, it is ensured that the connectivity between the sensors and the computing devices is maintained with very low down time.

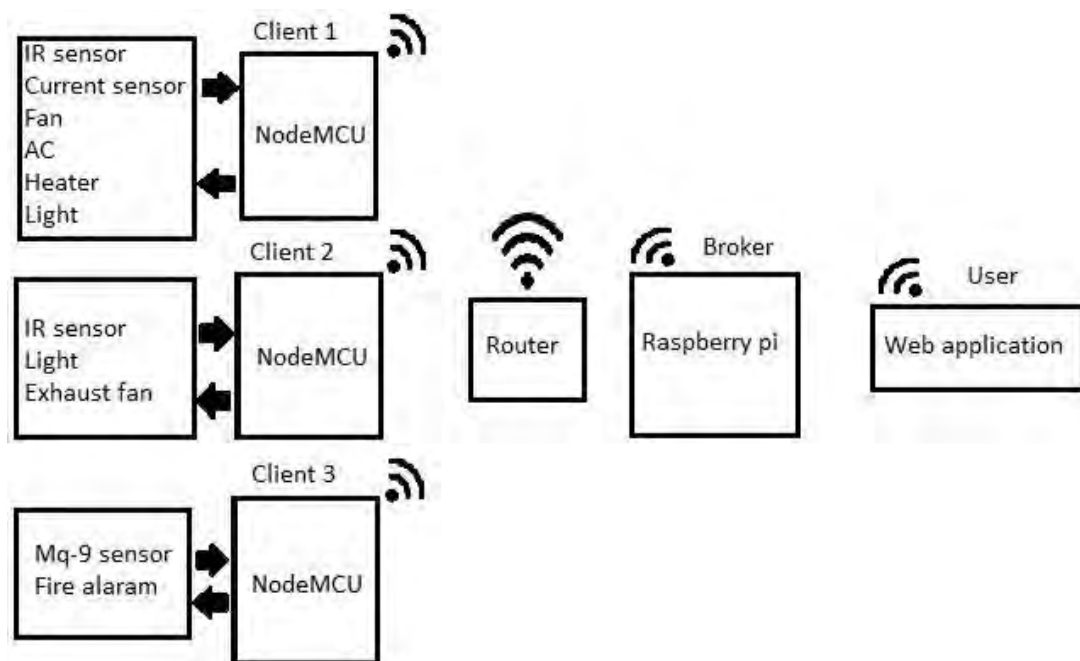

Fig. 2.1 Smart Office



## 2.2 Working

Fig. 2.1 shows the complete lay out of the project. Clients mentioned in the Fig. 2.1 are the microcontrollers (NodeMCU ESP8266). Each of the microcontrollers is fixed in different places. Client 1 is placed in room. Three sensors, infrared, current and temperature sensor, are connected to client 1 to control the appliances of room. Infrared sensor is fixed at door and it is detecting the motion whenever a person enters the room. Its purpose is to count the number of persons present in the room. If person is present in the room then the light, connected to a relay through NodeMCU is ON. If a user wants the light to remain OFF even when a human is in the room then a button of light in the web application must be set to OFF by the user otherwise light will get ON or OFF automatically according to the human presence. A temperature sensor is also connected to the client 1 and it is sensing the temperature of the room according to which a fan, AC or a heater is ON or OFF by the microcontroller. AC or heater are ON if a human is present in the room and the temperature of the room is greater than a threshold set by the user on web application. A current sensor is connected to client 1 and measures the power consumed by all appliances of office and updates consumption of current to web application.

Client 2 is placed in washroom. Only IR sensor is connected to client 2. IR sensor is placed at washroom door. It is detecting the presence of a person in the washroom. If presence of a person is detected by sensor then light and exhaust of the washroom are ON. When the person exits the washroom light is OFF immediately and exhaust is OFF after two minutes.

Client 3 is placed in lounge. Toxic gas sensor (Mq9) and an alarm is connected to client 3. Sensor is sensing the toxic fumes in office. Alarm is ON when the toxic fumes are detected in office and notification is generated on web application

All the three clients and a raspberry Pi (broker) are connected to router. Router is assigning dynamic IP addresses to clients and raspberry Pi. Router is used for creating communication network between all devices. Broker is used for exchanging the data between all clients and database. Web application is a user interface. This application is connected to database. Web application has all the information about the sensors data and all the thresholds are set by user using web applications.

## Chapter 3

### Components

#### 3.1 DHT 11

The DHT11 sensor consists of an element for measurement of humidity that is resistive and has a Negative Temperature Coefficient (NTC) temperature measuring factor and an eight-bit microcontroller for high performance, and offers an output signal with a calibration. It has highly reliable and feasible long-term stability.

##### DHT11 specs:

- Consumption: 0.3mA
- Range of temperature: 0- 50°C
- Accuracy:  $\pm 1\%$ ,  $\pm 1^\circ\text{C}$

**Table 3.1 Pin configuration:**

1	V <sub>cc</sub>	3.5 to 5.5V
2	Data	Outputs both temperature and humidity
3	Ground	Connected to the ground



**Fig. 3.1 DHT11**

### Role of DHT 11:

It is connected to a NodeMCU 8266 microcontroller. It senses the temperature of a room; microcontroller receives this data, sends to the Raspberry Pi, through MQTT protocol which is the centralized broker. Microcontroller checks whether to ON or OFF the relative electronic appliances and updates current status to the database. This database is accessible by the end user through a Web page. A user can set a specific level of temperature over that an appliance needs to be automated with the help of a web application.

Fig. 3.2 shows the working of DHT11 in this project. The temperature measured by the sensor seen on serial monitor of Arduino IDE is shown in Fig. 3.3.

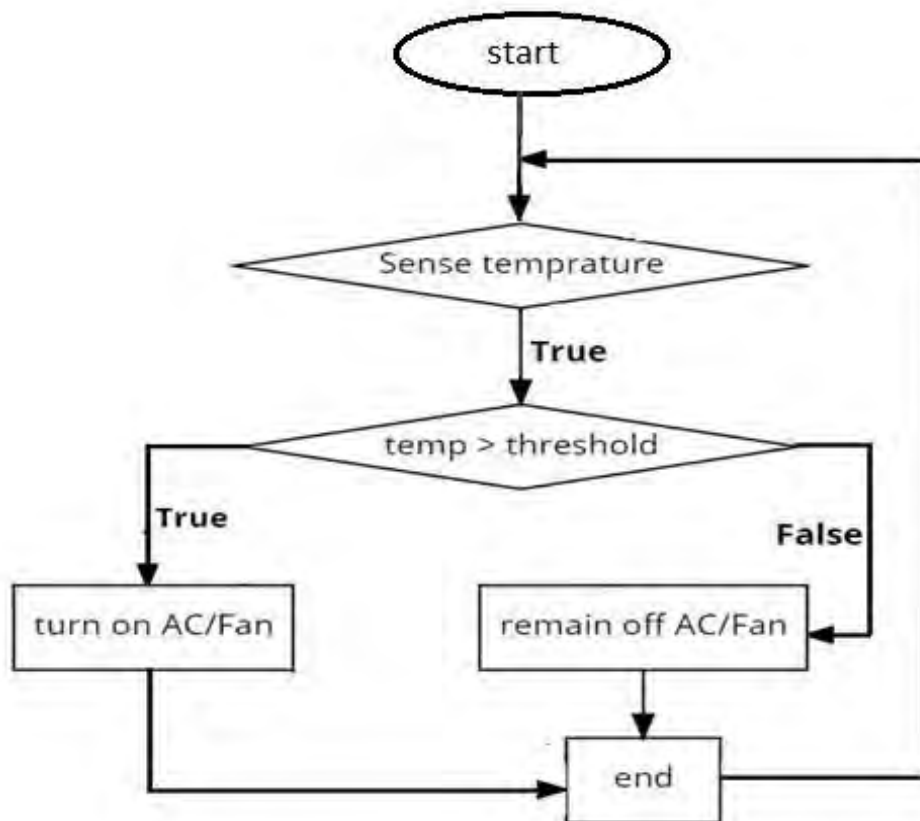

Fig. 3.2 Flow chart for temperature sensor

Temperature: 30°C  
 Temperature: 30°C  
 Temperature: 30°C  
 Temperature: 30°C  
 Temperature: 30°C  
 Temperature: 30°C  
 Temperature: 30°C  
 Temperature: 30°C  
 Temperature: 30°C  
 Temperature: 30°C  
 Temperature: 30°C  
 Temperature: 30°C  
 Temperature: 30°C  
 Temperature: 30°C  
 Temperature: 31°C  
 Temperature: 31°C  
 Temperature: 31°C  
 Temperature: 31°

**Fig. 3.3 Results by temperature sensor**

### 3.2 MQ 9

It is used for sensing carbon monoxide and flammable gases. It detects the carbon monoxide density from 10ppm to 1000ppm and density of flammable gases from 100ppm to 10000ppm. It has an internal heater that starts heating up if a 5V voltage is applied. Its internal resistance changes as the density of the gases changes. The value of the internal resistance is measured through a simple circuit.

For accuracy MQ 9 is pre-heated about 24-48 hours. For this purpose, it is connected to the power supply and it is left for the required time until it gets ready. Before using this sensor, calibration is necessary. The values are based on ratio of the resistances. The ratio is of  $R_0$  (resistance of sensor in 1000ppm concentration of liquid petroleum gas) and  $R_s$  (internal resistance changes by concentration of gas).

**Table 3.2 Pin configuration:**

V <sub>cc</sub>	5V
GND	Connected to the ground
A <sub>o</sub>	Outputs analog
D <sub>o</sub>	Digital output



**Fig. 3.4 Mq9**

**Role of toxic gas sensor:**

Mq9 is connected to NodeMCU and it senses the flammable gases. If any flammable gasoline is present over a detailed threshold an alarm related to microcontroller might be set on and standing can be updated at the web page to hold the give up user updated.

Flow chart in Fig. 3.4 shows the complete working of the sensor in project.

Fig. 3.5 shows the result obtained on serial monitor by the toxic gas sensor.

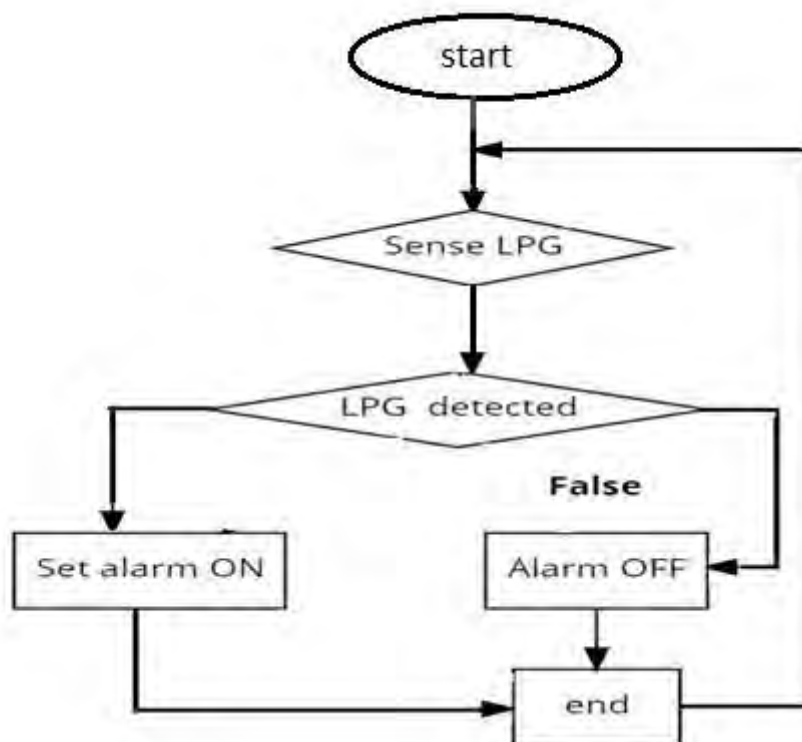

**Fig. 3.5 Flow chart for toxic gas sensor**

```

LPG = 0.57 V
LPG = 0.57 V
LPG = 0.57 V
LPG = 0.57 V
LPG = 0.58 V
LPG = 0.75 V
LPG = 0.97 V
LPG = 1.50 V
LPG = 1.59 V
LPG = 1.50 V
LPG = 1.84 V
LPG = 2.05 V
LPG = 2.00 V
LPG = 1.89 V
LPG = 1.93 V

```

**Fig. 3.6 Results by toxic gas sensor**

### 3.3 Current Sensor acs712

To sense and control the flow of current is one of basic requirement in many applications such as over-modern-day protection circuits, battery chargers, switching mode electricity materials, digital potentiometers and programmable modern source. This module is used to stumble on and sense each AC and DC currents. A maximum of 30A of AC or DC current can be detected through this module and signal can be detected through analog input output pin. Current sensor for 5A and 20A are also available.

**Table 3.3 Pin configuration:**

V <sub>cc</sub>	Input voltage
Out	Output voltage
GND	Ground

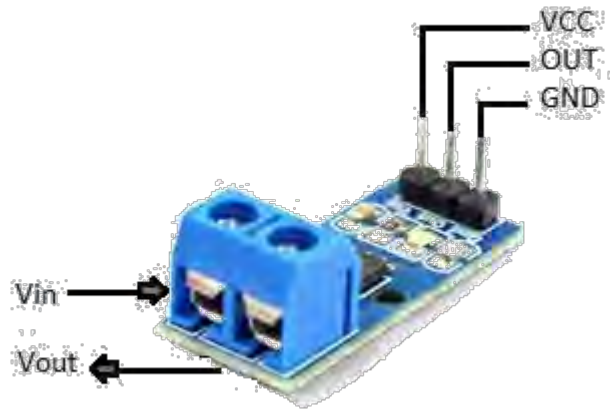

**Fig. 3.7 Current Sensor**

**Table 3.4 Pin configuration:**

Vcc	5V input
Output current range	$\pm 30(A)$
Output voltage	Half of $V_{cc}$
Scale Factor	66 mV/A

#### **Role of Current Sensor acs712:**

It is connected to the NodeMCU. All the current to appliances passes through the sensor. Sensor measures this current. NodeMCU reads the measured data from sensor and sends this to Raspberry Pi via mosquito broker. Raspberry Pi sends this data to the database from where it is sent to web app. User is updated through web page about current consumption records. Current sensor measures the current in milli Amperes.

### **3.4 Infrared sensor (motion sensor)**

Infrared (IR) sensor is used in automation of appliances and for security purpose. IR sensor detects the motion but it cannot identify the thing that moved.

#### **Feature:**

It has low noise. It has high sensitivity and delay time is adjustable. It has standard Transistor-Transistor logic (TTL) output

**Table 3.5 specifications of IR Sensor:**

Pins	Function
V <sub>cc</sub>	Connect to 3 volts
GND	Connect to ground
S <sub>o</sub>	Connect the output to LED

For wiring with ESP8266 it requires to connect three pins V<sub>cc</sub>, GND and output signal so it simply can be used for turn lights ON or OFF. When connectivity is completed then IR sensor will take 30s-60s to stabilize.



**Fig. 3.8 IR sensor**

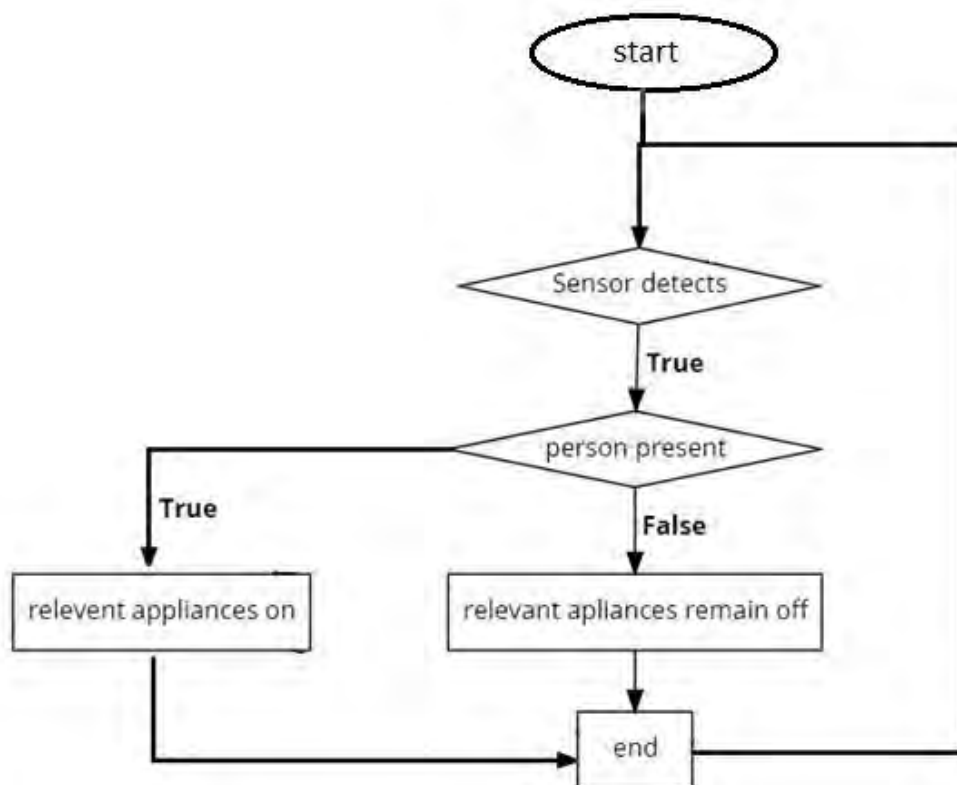

**Fig. 3.9 Flow chart for IR sensor**



**Role of IR Sensor:**

IR sensor is connected to NodeMCUESP8266, IR senses the motion and then sends the data to NodeMCU module, and NodeMCU sends data to Raspberry Pi through MQTT protocol, which is centralized broker. Microcontroller checks whether to ON or OFF the relative electronic appliances and updates current status to the database, this database is accessible by the end user through web application. User can also control the electric appliances through web application. If user is present in room but does not want to turn light on so light will be off through web application.

## Chapter 4

### Microcontroller

#### 4.1 Raspberry Pi

Raspberry Pi is developed by Raspberry Pi foundation UK (United Kingdom). It is a series of mini computers. Raspberry Pi was firstly introduced in 2012 and many versions of it have been launched since then. It has a size of credit card. The first release Raspberry Pi consists of a single core 256 MB RAM and 700 MHz CPU. The latest version has 1.4 GH of CPU and a RAM of 1 GB. The price of each Raspberry Pi is \$35, also the Raspberry Pi zero has a cost of \$5.

Raspberry Pi is globally used for learning programming, to build hardware for different projects, in Smart Office and for industrial level applications as well. It runs Linux OS and is low in price; however, it has a set of general purpose input/output pins.

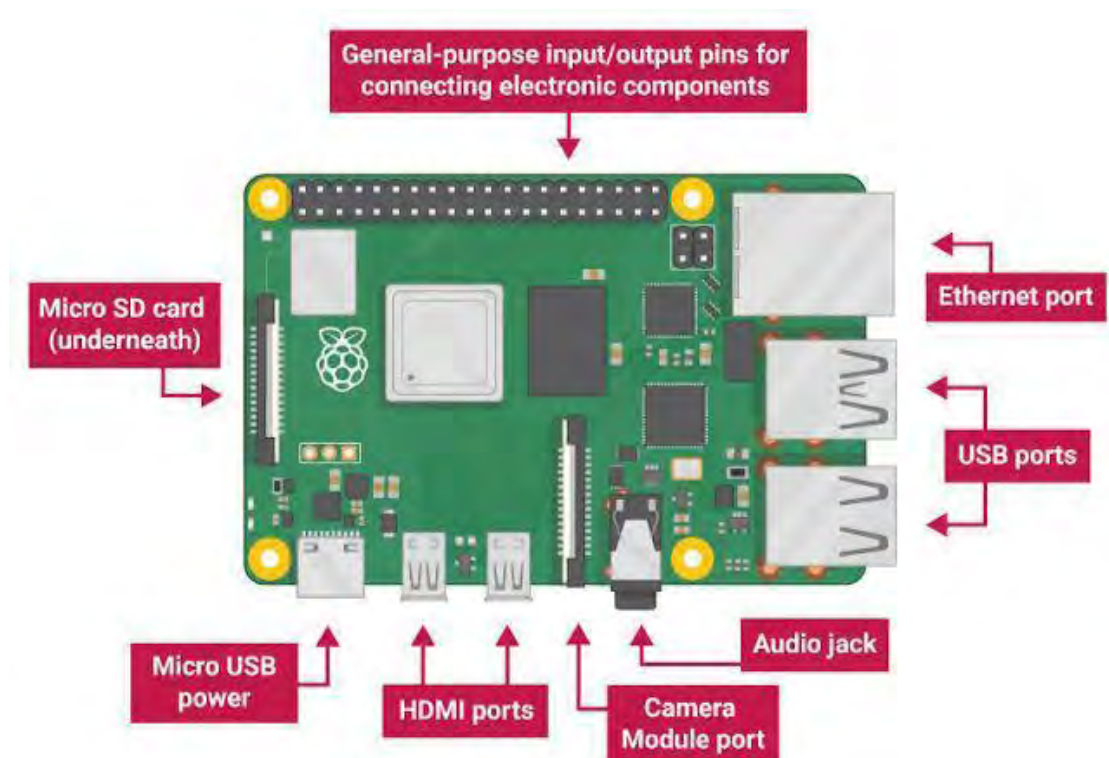

Fig. 4.1 Raspberry Pi 3

#### **4.1.1 OS (Operating system) of Raspberry Pi:**

The running system that is established in Raspberry Pi is Raspbian stretch.

Steps for installation:

In 1<sup>st</sup> step, Memory card of 8 GB is inserted to a card reader. The 2<sup>nd</sup> step is to download Raspbian stretch operating system and save it in desired drive in computer. Software used for burning operating system is win32 disk imager. 3<sup>rd</sup> step is to download and install win32 disk imager. 4<sup>th</sup> step is to open win32 disk imager, then select operating system from the drive where it was placed. Last step is to burn the operating system on the selected memory card. After the completion of all these steps successfully, eject the SD card from card reader and insert in the memory slot of Raspberry Pi. Then power on Raspberry Pi and operating system will start to install automatically. After the installation is completed, a language and current time is selected.

## 4.2 NodeMCU ESP E12

It is an IoT platform. It is open source. It is used for wireless network connections for microcontrollers; it is extension of ESPE8266 that is a highly integrated on chip, wireless system. It is low in cost and small in size but very useful. This module allows microcontroller to connect Wi-Fi and make simple TCPI/IP connection. It programs to control GPIO ports.

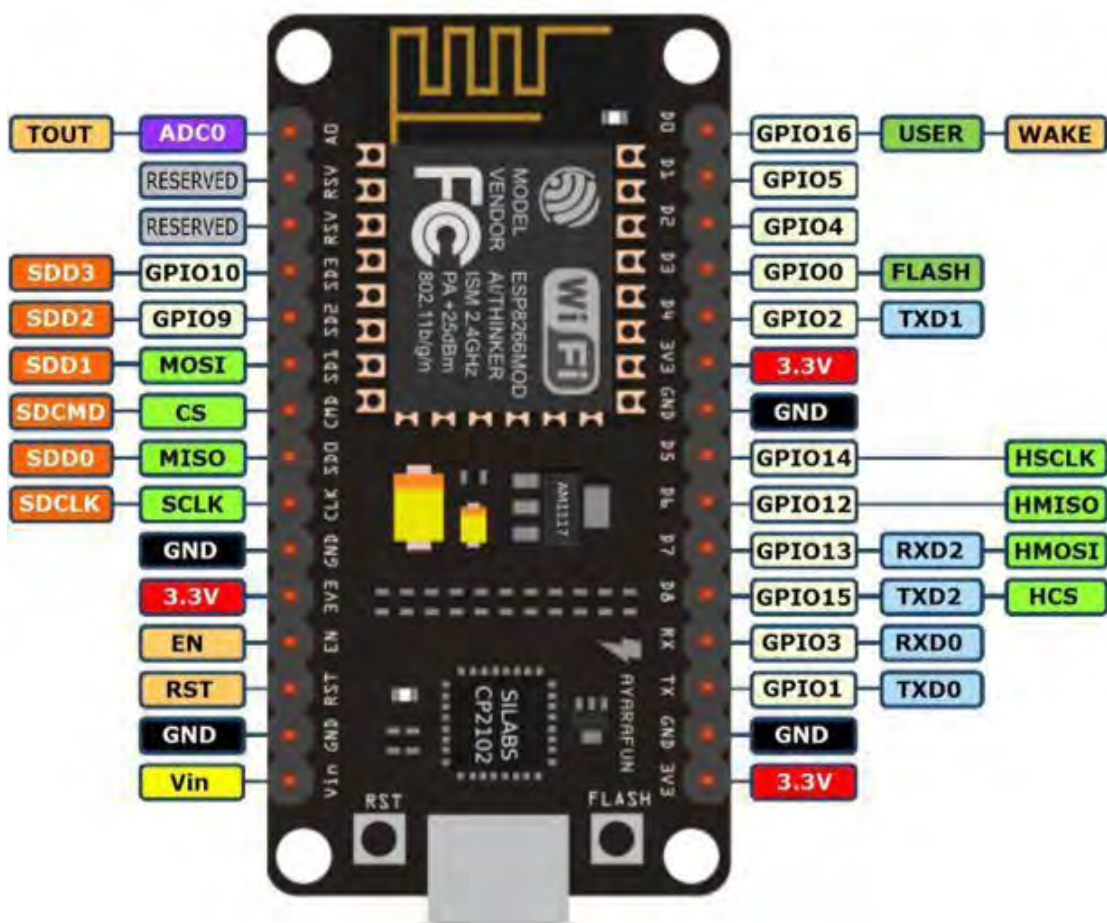

Fig. 4.2 NodeMCU

Table 4.1 Features:

Version	Devkitv1.0
Weight	Light
Power	3.3V
Language	C programming language

### **Ports of ESP E12:**

NodeMCU has 30 pins including 4 ground pins, 13 GPIO pins, 3 V<sub>cc</sub> pins.

ESP12E has an ESP8266EX inside it and NodeMCU is made up of it. With help of datasheet it can be checked, which pin is used to work with digitalWrite, digitalWrite, analogWrite, and analogRead.

**digitalWrite** is not compatible with 6, 7, 8, 11 general purpose I/O pins and ADC0

**digitalRead** is not compatible with 1, 3, 6, 7, 8, 11 general purpose I/O pins and the ADC0

**analogWrite** is not compatible with 6, 7, 8, 11 general purpose I/O pins and

ADC0 **analogRead** has compatibility with ADC (A0) only

## Chapter 5

### Database

#### 5.1 Introduction

A database is systematic collection of data that can be stored and accessed electronically from a computer. Database is used to make use of data easier. All data is inserted in tables, rows and columns and is also indexed to make it easy to find relevant data. In this project it is required to store all the data from all the sensors and to keep a record for further use.

#### 5.2 Goals

Database management system (DBMS) is used to resolve any redundancy and inconsistency of data. A user can access data easily. Its purpose is to solve the problem of data isolation as data is scattered in different files. It is used to ensure security by making database accessible to only authentic user. It is helpful in solving integrity problems.

#### 5.3 Components results on database

First step to start database by using the URL (<http://localhost.com> or <http://127.0.0.1>) provided by web hosting company.

Fig. 5.1 shows 16 tables created in the database. For the data of each sensor there is a separate table and other tables are to set thresholds. Each table has three columns. 1<sup>st</sup> column is for ID, 2<sup>nd</sup> is for the data of sensor and 3<sup>rd</sup> is for time and date to keep record of when the database is updated.

Fig. 5.2 shows the results obtained by the temperature sensor and different time and date. The rows of the table show different entries of data which are updated to the database and rows are increased by default auto increment and a log is created. This log has all the previous record of the data obtained by the sensors.

Fig. 5.3 shows the results from the automation of light. It has three columns. 1<sup>st</sup> column is for ID, 2<sup>ND</sup> for the data which is in the form of zeros and ones to show if the light is OFF or ON respectively, 3<sup>rd</sup> shows the time and date at which light is ON

or OFF .When light is ON, 2<sup>nd</sup> column of the table is updated with a '1' .When light is OFF, 2<sup>nd</sup> column is updated with a zero.

Table	Action	Rows
<input type="checkbox"/> fire_alarm	★ Browse Structure Search Insert Empty Drop	148
<input type="checkbox"/> humidity	★ Browse Structure Search Insert Empty Drop	1,145
<input type="checkbox"/> net_current	★ Browse Structure Search Insert Empty Drop	715
<input type="checkbox"/> remaning_water	★ Browse Structure Search Insert Empty Drop	5
<input type="checkbox"/> room_ac	★ Browse Structure Search Insert Empty Drop	236
<input type="checkbox"/> room_fan	★ Browse Structure Search Insert Empty Drop	593
<input type="checkbox"/> room_heater	★ Browse Structure Search Insert Empty Drop	233
<input type="checkbox"/> room_light	★ Browse Structure Search Insert Empty Drop	768
<input type="checkbox"/> room_light_manual	★ Browse Structure Search Insert Empty Drop	99
<input type="checkbox"/> temperatture	★ Browse Structure Search Insert Empty Drop	1,168
<input type="checkbox"/> threshoid_fire_alarm	★ Browse Structure Search Insert Empty Drop	3
<input type="checkbox"/> threshoid_remaning_water	★ Browse Structure Search Insert Empty Drop	18
<input type="checkbox"/> threshoid_room_ac	★ Browse Structure Search Insert Empty Drop	47
<input type="checkbox"/> threshoid_room_heater	★ Browse Structure Search Insert Empty Drop	27
<input type="checkbox"/> threshoid_room_fan	★ Browse Structure Search Insert Empty Drop	175
<input type="checkbox"/> washroom_light	★ Browse Structure Search Insert Empty Drop	776
<input type="checkbox"/> weight	★ Browse Structure Search Insert Empty Drop	8
<b>17 tables</b>	<b>Sum</b>	<b>6,124</b>

**Fig. 5.1 Tables of database**

			id	temperature	time and date	
<input type="checkbox"/>				8	32	2019-08-28 02:56:01.058447
<input type="checkbox"/>				9	34.1	2019-08-28 02:56:39.370889
<input type="checkbox"/>				10	29.4	2019-08-28 02:57:17.667351
<input type="checkbox"/>				11	28.5	2019-08-28 02:57:55.969729
<input type="checkbox"/>				12	28.1	2019-08-28 02:58:34.289416
<input type="checkbox"/>				13	27.9	2019-08-28 02:59:12.608643
<input type="checkbox"/>				14	27.8	2019-08-28 02:59:50.901012
<input type="checkbox"/>				15	27.7	2019-08-28 03:00:29.264150
<input type="checkbox"/>				16	27.7	2019-08-28 03:01:07.508218
<input type="checkbox"/>				17	27.6	2019-08-28 03:01:45.812637
<input type="checkbox"/>				18	27.6	2019-08-28 03:02:24.113644
<input type="checkbox"/>				19	27.6	2019-08-28 03:03:02.462516
<input type="checkbox"/>				20	27.6	2019-08-28 03:03:40.722721
<input type="checkbox"/>				21	27.6	2019-08-28 03:04:19.004458
<input type="checkbox"/>				22	27.6	2019-08-28 03:04:57.301667
<input type="checkbox"/>				23	27.6	2019-08-28 03:05:35.629255
<input type="checkbox"/>				24	27.6	2019-08-28 03:06:13.925654
<input type="checkbox"/>				25	27.6	2019-08-28 03:06:52.239242

Fig. 5.2 Results of temperature

				id	room_light	time and date
<input type="checkbox"/>				1	1	0000-00-00 00:00:00.000000
<input type="checkbox"/>				2	0	0000-00-00 00:00:00.000000
<input type="checkbox"/>				3	1	0000-00-00 00:00:00.000000
<input type="checkbox"/>				4	0	0000-00-00 00:00:00.000000
<input type="checkbox"/>				5	1	0000-00-00 00:00:00.000000
<input type="checkbox"/>				6	1	2019-09-12 16:42:41.616653
<input type="checkbox"/>				7	0	2019-09-12 16:43:27.778259
<input type="checkbox"/>				8	1	2019-09-12 16:43:41.952074
<input type="checkbox"/>				9	1	2019-09-12 16:44:24.852880
<input type="checkbox"/>				10	1	2019-09-12 16:44:58.894987
<input type="checkbox"/>				11	0	2019-09-12 16:45:03.677299
<input type="checkbox"/>				12	0	2019-09-12 16:45:10.702947
<input type="checkbox"/>				13	0	2019-09-12 16:45:16.284047
<input type="checkbox"/>				14	0	2019-09-12 16:45:25.278408
<input type="checkbox"/>				15	0	2019-09-12 16:45:29.218511

Fig. 5.3 Results of room light



## Chapter 6

### MQTT protocol

#### 6.1 MQTT introduction

MQTT or MQ telemetry transport is a standard of ISO (International organization for standardization). It is publish-subscribe based protocol for messaging. Its purpose is to provide connections between remote areas where the network bandwidth is limited. It is used in sensors communication to a broker via satellite link, in office automation and tiny device situation. It is beneficial for mobile application because of its small length, less electricity intake, minimized statistics packets and higher distribution of records between many devices.

#### 6.2 MQTT architecture for publish-subscribe

It sends messages asynchronously through Pub-Sub architecture. It exchanges a series of MQTT manipulate protocols in a well-described manner. Purpose of each protocol is particular, and each little bit of packet is transmitted carefully to lessen the data transmitted over the network. In MQTT topology there is a MQTT server and a MQTT client which talk with every other thru unique manipulate protocols.

#### 6.3 Ideal for limited networks

MQTT has small size headers. This service control packet has 3 components:

- A header of the fixed length of two bytes
- A payload
- Variable header

But all the control protocols don't have variable header and payload. If a control protocol requires an identifier then it is contained in variable header. A payload that can be attached to a protocol has a size of 256MB. Small size of header makes it suitable for IOT through reducing the statistics transmitted over restrained networks.

## 6.4 Quality of service of MQTT

The level of quality of service indicates that how messages are being sent and it should be specified for each message to send through protocol. Hence, it is important to choose adequate level of QOS for each message.

- QOS<sub>0</sub> (At most as soon as) - wherein messages are delivered in accordance with the pleasant efforts of the working environment. Message loss is also possible.
- QOS<sub>1</sub> (at least as soon as) - wherein messages will surely reach but duplicates can take place.
- QOS<sub>2</sub> (exactly once) - in which message are sure to reach exactly as soon as possible

The performance is low with higher QOS. MQTT gives enough flexibility to devices of IOT to select such value of QOS which are required for better functions and are according to environment.

## Chapter 7

### Web Application

#### 7.1 Background

A web app is a program that is stored on a server and can be accessed through internet using a browser. By using a web app, a user can acquire and manipulate data. It is also accessible through a mobile, laptop or desktop computer using a variety of browsers.

#### 7.2 Web application interface

The title of the web application is IoT Connected Smart Office Applications. There are two tables of which, one is used for title and the other for data. In 2<sup>nd</sup> table there are four columns and in each column, there are nine rows. First column is for name of different appliances, second for the current status of each appliance, third for the status of threshold set by the user and fourth one is for changing the threshold. A user can use the insert button to change the threshold temperature to turn on or off the fan, AC or heater. There is also a button to turn light on or off if a user does not want to allow it to turn on and off automatically. Second row is for room lights, next is for fan, AC heater, temperature, humidity, washroom lights, fire alarm and net current respectively. Status tells that if the fan, ac, heater or light is currently on or off. The status of the threshold tells what the temperature is set by the user. And the column next to the temperature tells the current temperature of the room according to which a user can set the threshold to turn on and off the appliances.

IoT Connected Smart Home Applications			
Name	status	Threshold status	Change threshold
Room Lights	On	On	<input type="text" value="Manual on/off"/>
Room Fan	On	25	<input type="text" value="insert"/>
Room AC	On	22	<input type="text" value="insert"/>
Room Heater	On	33	<input type="text" value="insert"/>
Temperature	33°C		
Humidity	95 %		
Washroom Light & Exhaust	Off		
Fire Alarm	Off		
Net Current	6.73 A		

**Fig. 7.1** web application

## Chapter 8

### Implementation

The designing method of the project has foremost portions: software layout and hardware design. The hardware is designed by way of arranging microcontrollers, sensors and actuators while software layout consists of programming this is written and uploaded within the microcontrollers. The design shows microcontroller linked to sensor-modules and actuator-modules for monitoring and controlling. This design section indicates how special hardware components are set up. The specifications and information concerning numerous components are described underneath. The system is modeled to screen statistics from three sensor-modules and control loads by using cellular software. The various purposeful units used within the machine are as follows:

- 1. NodeMCU:** (Microcontroller). It is the principal co-coordinator of the sensors and the actuators. This microcontroller has integrated aid for Wi-Fi connectivity which permits it to send and acquire data from mobile software through Internet server. It reads sensor statistics and sends them to cell software and receives commands from cell utility to manipulate office appliances. It then drives the relay-module to control the office equipment.
- 2. Sensor modules:** They get hold of records approximately current ambient conditions in domestic surroundings and ship them to NodeMCU.
- 3. Web application:** A platform with HTML provides widgets to show sensor statistics obtained from NodeMCU and manage output alerts (to control loads) from NodeMCU to the actuator circuits.
- 4. Internet server:** Cellular application in telephone and NodeMCU talk by means of the use of online server. Bidirectional switch of records among NodeMCU and web application happens via this server.

## **Chapter 9**

### **Conclusion**

Smart office is an important application of internet of things (IoT). It makes the life of a user easier and comfortable. IoT plays an important role in security and energy saving. The endeavor to achieve maximum accuracy is made, in this project. The system comprises of sensors, Raspberry Pi, NodeMCU, and the Internet. Wi-Fi technology is used for easy integration with the existing hand held devices (mobile phone etc.) and web app. It is ensured that the connectivity between the sensors and the computing devices is optimal. Web application is used to examine information from sensors located in domestic/office environment and consumers control domestic appliances based on that information that is stored in database.