

OBD2 (On-Board Diagnostic II)



Arslan Ali

Department of Electronics

Quaid-i-Azam University

Islamabad

2019

Contents

| | |
|---|-----|
| <i>Dedication</i> | v |
| Abstract | vii |
| Chapter 1..... | 1 |
| Introduction | 1 |
| 1.1 Project Overview | 1 |
| 1.2 Background..... | 2 |
| 1.3 Objectives and Motivation | 4 |
| 1.4 System Architecture..... | 4 |
| 1.4.1 Diagnostic System Architecture..... | 6 |
| 1.4.2 Logging Data | 7 |
| 1.5 Significance of Proposed Work | 7 |
| Chapter 2..... | 8 |
| Literature review..... | 8 |
| 2.1 Universal OBD-II Scan instrument:..... | 8 |
| 2.2 A Prototype System | 9 |
| 2.3 Elimination of Fault Codes | 9 |
| 2.4 Fleet Monitoring | 10 |
| 2.5 Standard Protocols | 12 |
| 2.6 Vehicle Communication Interface | 13 |
| Chapter 3..... | 15 |
| Hardwar Design and Implementation..... | 15 |
| 3.1 Main Hardware Components Used..... | 15 |
| 3.2 STN1110..... | 15 |
| 3.2.1 Characteristics:..... | 15 |
| 3.2.2 STN1110 V/S ELM327 ICs..... | 17 |
| 3.3 LM399PWR (Comparator)..... | 18 |
| 3.3.1 Characteristics:..... | 18 |
| 3.3.2 Functions:..... | 18 |
| 3.4 "LM317LD" (Positive /Electrical energy Regulators)..... | 19 |
| 3.4.1 Characteristics:..... | 19 |
| 3.4.2 Features | 19 |

| | |
|---|----|
| 3.5 MCP2551 | 20 |
| 3.5.1 Characteristics:..... | 20 |
| 3.6 78M05 (5V Voltage Regulator)..... | 21 |
| 3.6.1 Characteristics..... | 21 |
| 3.7 AME1117 (3.3V Voltage Regulator)..... | 22 |
| 3.7.1 Functions:..... | 22 |
| 3.8 Diodes | 23 |
| 3.8.1 Description:..... | 23 |
| 3.8.1.1 Features | 23 |
| 3.9 Transistor: | 23 |
| 3.9.1 2N3904..... | 23 |
| 3.9.1.1 Feature..... | 23 |
| 3.9.2 2N3906..... | 24 |
| 3.9.2.2 Applications | 24 |
| 3.10 DLC (Data Link Connector) | 24 |
| 3.11 Bluetooth Serial Interface Module..... | 25 |
| 3.12 Hardware Implementation..... | 26 |
| 3.12.1 Block Diagram | 26 |
| 3.12.3 Circuit Diagram..... | 28 |
| Chapter 4..... | 30 |
| Testing and Results | 30 |
| 4.1 Testing OBDII Hardware..... | 30 |
| 4.1.1 Testing Through Teraterm Terminal..... | 30 |
| 4.1.2 Real Time Testing..... | 31 |
| 4.1.3 Project folder Data and Its Output | 33 |
| Chapter 5..... | 34 |
| Application & Conclusion..... | 34 |
| 5.1 User Applications..... | 34 |
| 5.1.2 Enterprise applications..... | 34 |
| 5.2 Informative supplement D | 35 |
| 5.2.2 OBD-II as a Standard Connector and Protocols:-..... | 36 |
| 5.2.3 Deciding PROTOCOL FROM OBD-II PINOUT..... | 36 |

| | |
|---|----|
| 5.2.4 OBD-II Signal Protocol Description..... | 36 |
| 5.2.5 OBD-II Diagnostic Data | 38 |
| 5.3 What is DTC | 39 |
| 5.4 Conclusions | 39 |
| References: | 40 |

بِسْمِ اللَّهِ الرَّحْمَنِ الرَّحِيمِ

Dedication

We dedicate this work to my respected teachers who helped us and taught us such great skills to develop this project and my beloved parents and family who supported us in every phase during our project and degree as a whole. I thank my friends, who supported me during the thesis work and stood with me through every thick and thin.

Arslan Ali

Acknowledgments

Allah Almighty be praised Who granted me the courage and ability to complete this thesis. I express my highest gratitude to my project supervisor, Dr. Hasan Mahmood, who encouraged me and guided me throughout my project. His intellectual guidance, cooperation, kind interest and counseling in this research work will always serve me throughout the course of my life. I am heartily thankful to my supervisor for thesis compilation and formatting.

I express gratitude towards Allah for that he gave me strength and wisdom to understand my research work. For sure, for the duration of my life: “I can do everything through Him Who give me strength.”

I am highly indebted to my supervisor for his constant coordination and mentorship in the completion of my thesis. I own special thanks to my family for their moral support and encouragement.

Arslan Ali

05 January, 2019

Abstract

In this work, we create a framework to efficiently connect and acquire data from commercial automobiles. A system that proficiently monitors and administers the vehicles operating parameters and its performance is difficult to design and realize. We design a circuit to achieve connectivity for vehicles equipped with an on-board diagnostics computer—second generation (OBD-II) computer. The engine control unit (ECU) is accessed and the data is processed for diagnostics and analysis by using STN1110 mediator integrated circuit. The Bluetooth interface is used to provide connectivity to the OBD-II computer and the users monitor and operate the system through a mobile phone application. An efficient interface is provided to troubleshoot engine errors, emission errors and other automobile system errors.

Chapter 1

Introduction

1.1 Project Overview

A widespread on-board diagnostics-second generation (OBD-II) access apparatus, utilizing a PIC microcontroller, STN1110 IC is created to access data from vehicle electronic control unit (ECU). The STN_1110 is (UART to OBD) translator integrated circuits that change our data between them. This integrated circuit associates with Bluetooth at one side and on-board diagnostics (OBD-II) connector on the opposite side. Then an interface is associated with Bluetooth, which can be a cell phone or PC programming. Client can spare diverse data from has specific means of transportation by influencing follow to record in some item applications and after that drive this record archive to an enterprise resource planning.

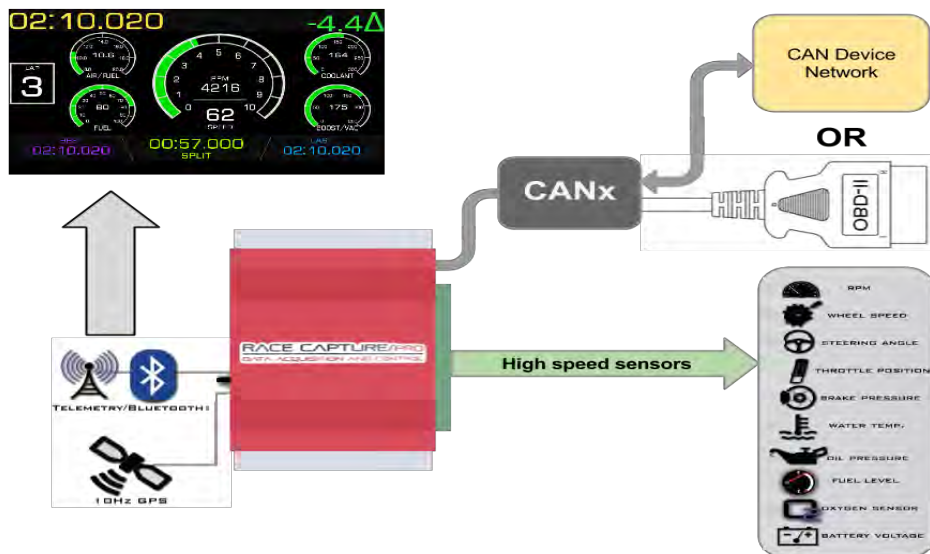

Figure 1.1 Block diagram of (OBDII)

1.2 Background

OBD-II remain for Second Generation on-board diagnostic framework. It gives an arrangement of guidelines for vehicle's self-symptomatic and detailing ability. An expansive number of new vehicles support OBD-II. To examine and work with OBD-II framework each reliable vehicle should have:

1. 16 pins “Data Link Connector (DLC)”
2. A standard method to speak with the vehicle's Programing Controlling (PC) otherwise called ECU mainly known as electronic control unit.

Countless is acquired from ECU through OBD framework. For instance the status of the malfunction indicator light (MIL), diagnostic trouble codes (DTCs), data inspection maintenance (I/M), solidify outlines, Vehicle ID Numbers (VIN), several constant parameters and some more.

In car hardware, ECU is a general term utilized for any installed framework that controls at least one electrical framework in means of transport. Various kinds of ECU which includes “Engine control module (ECM)” , “Brake control module (BCM/EBCM)” , “Power prepare Control Module (PCM)” , “General Electronic Module (GEM)” , “Transmission control module (TCM)”, “Central Control Module (CCM)”, “Body Control Module (BCM)”, “Suspension control module (SCM)”. All the above described frameworks taken together are at times called auto PC. Most recent autos have up to at least 80 ECUs. Expanding many-sided quality and dealing with the quantity of ECUs in means of transport has turned into a solution test for new hardware

makers. The On board Diagnostic System was made to control and screen vehicle debilitate outflows. At second generation of its advancement, the OBDII presently bolsters

Unique composes of conventions went for a wide range of vehicles. The issue that emerges is that the vehicles may not utilize the conventions on the predetermined technique of pin outs and DLC rules and controls, so an immediate need is to plan a gadget that would bolster all or most 12 correspondence conventions and have an exchange and output system for effectively building up correspondence to any vehicle.

Current OBD Systems make utilization of an advanced institutionalized (ISO institutionalized) link called as the DLC for intercommunication amongst host and OBD. AT charges are a particular correspondence route amongst have and the OBD mediator IC (for our situation STN1110). They are called AT charges because of the perception that they begin with "AT" took after by xx, where xx is any alphanumeric worthy mix by the mediator IC. The correspondence begins with three bytes of demand code and an answer may comprises as large as seven bytes of data in which begin bit, stop bit, equality and checksum are included side by side in a standard organization indicated by the Society of Automotive Engineer (SAE). The checksum is made by the translator to make correspondence simple. The breakdown of correspondence is given underneath:

1. First byte = "MODE" determines the sort of information required,
2. The second byte or more bytes = "PID" (parameter distinguishing proof) determine the asked for data.

Generally the main demand sent by the host is AT00 which indicates the quantity of OBD parameters upheld by the Vehicle. ERP framework is a stage utilized for the administration of business. This is an incorporated application that can be used to oversee and store information by an association. ERP framework gives an ongoing perspective of essential business forms by utilizing basic database. It facilitates data stream between all business works and oversees associations with outside partners.

1.3 Objectives and Motivation

There are distinctive OBD-II Scan instruments accessible for vehicle diagnostics, yet these are particular in their capacities and are perfect just with vehicles having the same OBD-II standard as checking gadget have. Additionally, a portion of these demonstrative instruments have staggering expense neither excessively proficient nor easy to understand. Likewise, programming answers for vehicle administration and execution enhancement are exorbitant. Along these lines venture destinations are:

1. A minimal effort general OBD-II checking gadget that is perfect with each sort of vehicle, for constant observing and enhancement of car's execution.
2. To build up a vehicle execution improvement module in Open ERP.

1.4 System Architecture

Vehicle wellbeing and situating telemetry framework is a method for observing status of motor condition, area, developments, status and conduct of a vehicle or armada of vehicles. This is

accomplished through a remote gathering of information through a blend of equipment gadgets introduced in a vehicle, correspondence innovations and software's. With the headway of new standards of innovation, it is winding up simple to oversee and control vehicles through telemetric frameworks. Undertakings having substantial armada of vehicles are confronting difficulties of administration and execution improvement. Consequently, a telemetry framework is created for ideal administration through continuous observing of vehicle wellbeing and its situating.

Equipment and programming stages are required for removing, logging, detailing and examination of vehicle wellbeing and other information. This information from vehicle is gained through on-board diagnostic (OBD) framework & engine control unit (ECU). There are a few sensors 14 accessible in the vehicles which are associated with the ECU. One can speak with an ECU through interfacing an OBD examining instrument in OBD information interface connector or port, as OBD framework has then made it simple to extricate information from the motor. The most recent innovation being used is OBD-II and there is a 16 stick OBD-II connector, in the vast majority of the autos made after 1996 models. One can see data, for example Mileage, mpg, fuel utilization, mistake codes, air or fuel proportion, timing and numerous different parameters relying upon the sensors accessible in the particular vehicle to see the execution of it.

Correspondence innovations and programming's are utilized to see this OBD framework information. There are numerous approaches to peruse the information utilizing android gadget or work area application. A portable work area or web application through a Bluetooth or Wi-Fi associates with the "OBD" scanner. These applications are utilized to get information from (OBD) scanner. Additionally, the client is capable to spare the information into log documents on the cell phone or PC. So also, the information can be sent to the Enterprise Resource Planning

(ERP) framework in an association, in the nick of time to the repair and up keep office, where it is assessed to recognize the issues or to identify abnormalities, and can help for dealing with the execution of vehicles in an ideal way.

1.4.1 Diagnostic System Architecture

OBD-II framework can be isolated in 3 sections from the viewpoint of layering of OBD-II framework symptomatic convention the various characteristics in physical layer, connection level and matchlessness in function level. PC symptomatic programming is the essential piece of the diagnostic framework. This gives human PC communication line, and achieves the function level of the convention. In addition, this is enables just only help to post which join vehicle data through web. Consequently a diagnostic framework is organized and the limit of benefit bestowing and remote diagnostics could be accomplished. Vehicle communication interface (VCI) framework is the scaffold which associates the vehicle indicative framework and host PC determination framework. It actualizes the change of various correspondence conventions amongst system and host PC finding framework.

At the point while auto is affecting, ECU always screens in sequence data of sensor and actuators through CAN. When it identifies at least one blame data, it will light up the MIL and afterward store the blame data as analytic codes into memory. When diagnosing issues, analytic gadgets speak with ECU and get the capacity blame codes and other data, as indicated by symptomatic conventions utilized.

1.4.2 Logging Data

Information of accessible sensor can be logged and put away in log petition for assist examination. The record is in CSV arrange for the most part store in the log envelope of the accessible programming.

1.5 Significance of Proposed Work

OBDII framework requires all light obligation autos and trucks to screen particular frameworks utilizing nonspecific criteria for assessment and revealing of framework status, and for showing issues to the driver as well as professional. OBD-II code gives definitions, depiction, indications and a conceivable arrangement of vehicles flaws.

Utilizing this OBD-II examine instrument one can without much of a stretch analyze vehicle and can maintain a strategic distance from various mishap because of shroud disappointments in vehicle. Likewise future blames in vehicle are effectively analyzed. Likewise for armada administration association, it gives a superior and modern method for diagnosing and observing status of motor condition, area, developments, status and conduct of a vehicle.

Chapter 2

Literature review

Automatization of vehicle is critical field and is begun since 1990s. Numerous researchers contribute around there and accomplish numerous critical objectives. Bunches of equipment are made and numerous strategies and techniques are connected to accomplish proficiency in automization of vehicles. In this part, couple of strategies and methods of locally available indicative framework building is quickly portrayed. This part essentially center around portrayal about related work on OBD-II framework and OBD-II checking gadgets. A draw of ERP framework and its related work are likewise characterized. Writing survey covers the OBD-II framework examination, Data Collection, Monitoring Performance, Effectiveness examination and activities in light of test information, Fleet administration, Managing Young/Amateur Drivers, Preventive measures, Proactive measures.

2.1 Universal OBD-II Scan instrument:

OBD is a very important component in automization vehicles and machinery. Jie and H. Fuwu (2010, March) Developed PC-Based Automobile Diagnostic System Based on OBD System. Automobile diagnosis has been taken into considerations at the start of 1970 in the form of sensors embedded in them.

Today, the international manufacturers all over the world have successfully adapted OBDII as the standard for checking, maintaining, diagnosing and removing faults in automobiles in order to eliminate environmental risk due to emissions of toxic gases and particles.

2.2 A Prototype System

Roscaet Al (2011) created and depicted the plan, advancement, and information preparing qualities of the model framework. A microcomputer-based multichannel information securing framework is utilized to gain high recurrence transient data exemplified by, yet not constrained to, car vehicle crash test applications. The framework was intended to be mounted on the test vehicle amid a vehicle crash, will suit up to 240 channels. Each channel is included a remain solitary microcomputer, memory for information stockpiling, flag molding for piezo-resistive transducers, programmed adjustment and zero counterbalances, also, programmable pick up speaker. The microcomputer depends on a Motorola 6801/68701 microcomputer.

2.3 Elimination of Fault Codes

The on-board diagnostic (OBD-II) gauges were discharged and set up as a measure to deal with the vehicular outflows. The engine control unit (ECU) continually screens the different parts of the vehicle for any conceivable blames, for example, a motor fizzle, or a high temperature or a disappointment of the torque framework. Upon disappointment or identification of a mistake, the ECU stores that information in a memory area of the ECU called as the stop outline memory. Stop outline is a preview of the data of the considerable number of sensors at the time of event of blame. In the event that we center on the preventive side of the conceivable uses of a remote information scanner gadget, there is no or rare work accessible. OBDII is represented considerable authority it might be said that it has relegated alphanumeric codes to blunders that may happen in the car. So at the event of the blunder, the information is put away and a Diagnostic Trouble Code is set in the ECU which can be perused in the memory of the ECU by

the scanner gadget and afterward attempt to dispense with it. The ECU of a vehicle stores just blames and DTCs when there is a real mistake in the vehicle. The gadget:

1. Identify and transmit blame codes to the host
2. Foresee deficiencies that may happen with time 19 Worldwide Information System (GIS) is used in the vehicle and the area of the vehicle is additionally being transmitted to the server through mobile phone's General Packet Radio Service (GPRS) framework.

2.4 Fleet Monitoring

Siegel, J. E. (2011) plan and built up a slightly reconfigurable means of transport telemetry framework for customer and management functions. Government and endeavors are looking for approaches to control vehicle through web based observing framework in light of the social determinants, cost advancement, vehicle's wellbeing. This framework will give methods for charging, checking, security and control over calamity and mishap preventive techniques as well as advancement methods for vehicles administrations. Customers will welcome the measure of data that their autos will input to them through cell phones or online applications. Barely any perspective on-board diagnostic system attempt to cover.

1. Data Collection
2. Monitoring Performance
3. Efficiency examination and activities in view of test information
4. Fleet administration
5. Managing Teenage/Amateur Drivers
6. Preventive measures

7. Proactive measures.

No such framework is made as of not long ago which can handle all the previously mentioned perspectives. By and by simply handheld independent devices are available for diagnostics motivations behind distinguishing flaws and diagnostics inconvenience codes related with vehicle control units. Issues with this handheld independent gadget are:

- Engine parameters estimation isn't done unreservedly for computations purposes.
- Real time criticism isn't given.

20 Joined States Environmental Protection Agency (EPA) has ordered that the DTCs ought to be set just when there is an outflow out of hand extends. In any case, producers have modified their vehicles to trigger DTC occasions in view of any flaws in the vehicle. Consider a situation in which no DTC is set however there is a positive issue in the vehicle's working. So all things considered, we may require information got from the OBD scanner for the reason for killing and remedying flaws for streamlining and preventive measures. An expert may at some point utilize his good judgment and instinct to recognize flaws in view of encounter. Be that as it may, these techniques are tedious and tiring. So an all-inclusive scanner is required with cutting edge diagnostics capacities to all the more likely adapt to these MIL, DTC and other obscure mistakes for the wellbeing and security and execution streamlining of hardware. OBD is in charge of observing:

- Catalytic converters
- Evaporative control framework
- Emissions control framework
- Oxygen sensors

- Emissions related sensors and actuators
- Engine fizzle
- Exhaust gas distribution (EGR)
- Fuel framework
- Closed circle framework execution and so forth .

2.5 Standard Protocols

OBD-II Standards are introduced inside the Engine Control Unit (ECU) mainly identified as controls prepare power Module of the means of transport (PCM). OBD-II check instrument is utilized for the removal of valuable data from vehicle. A number of the OBD_II check instrument related gadgets are accessible in showcase e.g. individual computerized partner Dyno or OBD-II examine apparatus, Car chip armada, Driver Right 600, Scan Gauge. In any case, there might be a few restrictions in such gadgets so to bolsters all the 21 includes combine an all-inclusive OBD-II filter device is required with help of ISO, "SAE" institutionalized OBD-II. There are 5 correspondence conventions use for recovering information from OBD-II which takes after the SAE J1979 standard normal indicative test mode. These five conventions are - SAE J1850 (PWM), -SAE J1850 (VPW), -ISO 9141-2, -ISO 14230-4 (KWP 2000), -ISO 15765-4 (CAN).The information traverse OBD-II is then display on controller data framework "DIS" that is connected by OBD-II. It moreover gives information taking down to utilizing mixed media license appended in USB opening of personal computer.

2.6 Vehicle Communication Interface

The interface is vital for correspondence with vehicles. The interface is required for correspondence of utilization layer with physical layer. The physical layer is essentially the

electronic control framework for this situation. The Structure of car electronic control framework turns out to be increasingly confused with the expanding utilization of electronic control innovation. Finding the reason and position of issues in vehicles is troublesome. Vehicle comprises of Engine Control Unit (ECU) having associations with various sensors. At the point when vehicle begins start, ECU continually screens the approaching data of sensors connected it. When it identifies any blame it will flicker the blame marker (MIL) and store the 22 approaching flaw data in the memory as symptomatic codes. At the point when demonstrative gadgets speak with ECU it will recover the capacity blame symptomatic codes and other data from the memory, as per symptomatic conventions happen in demonstrative gadgets. OBD frameworks can investigation various types of analytic convention utilize on OBD symptomatic framework. By and by, generally utilized indicative hardware is OBD-II. Work area based symptomatic programming is utilized to analyze the framework which is the principle part of symptomatic framework. It gives human-PC correspondence interface. The vehicle symptomatic framework and analytic programming can be associated with the assistance of vehicle Correspondence Interface (VCI) framework. This framework is utilized for information transmission too as transformation of various correspondence conventions amongst system and PC.

There are three sub module of Vehicle Communication Interface (VCI) framework.

1. Convention transformation work module: This module is utilized for level transmission between vehicles convention and PC (Host).
2. Host micro-controller module: This module is utilized for examination the on board information what's more, send message to Host and in the meantime get information from have.
3. USB connect module: This module is utilized to exchange serial information to USB information and guarantee the correspondence among-est micro-controller and the Computer (have).

Chapter 3

Hardware Design and Implementation

Equipment is the center piece of our venture. The equipment comprises of different parts where STN1110 IC is the primary segment of equipment. The capacity and structure of every part are exhibited in the accompanying area. Brief testing and execution of this equipment is done utilizing a breadboard. Recreation and Schematic of this framework was planned utilizing diverse programming for example, Proteus, Eagle what's more multiuse and so on.

3.1 Main Hardware Components Used

The accompanying parts are utilized amid equipment execution: STN1110 IC, LM399PWR IC, LM317LD IC, MCP2551 IC, 78MO5 IC, AME1117 IC, 1N4148 Diodes, 2N3904 and 2N3906 Transistors, DLC and different resistors.

3.2 STN1110

This little but also least rate of "PIC" multiprotocol OBD to UART translator Integrated Circuit is "STN1110". With the assistance of STN1110 one can without much of stretch access vehicle information, for example, indicative inconvenience code, MIL readiness, assessment and preservation data. ELM327 order sets have complete upheld by "STN1110". This Integrated circuit depends on PIC smaller scale regulator that is actualized on PIC24HJ128GP502 position relations. This bolsters all AT order same like ELM327. Moreover it underpins ST charges sets.

3.2.1 Characteristics:

The Integrated circuit be upheld every enacted OBD-II conventions. For example,

- ISO 15765-4 (CAN)
- ISO 14230-4 (catchphrase convention 2000)
- ISO 9141-2 (Asian, European and Chrysler vehicles) 26
- SAE J1850 VPW (GM vehicles)

Additionally it have bolster for non-administered OBD-II conventions. For example,

- ISO 15765
- ISO 11898

Furthermore bolster for SAE J1939 OBD_II convention.

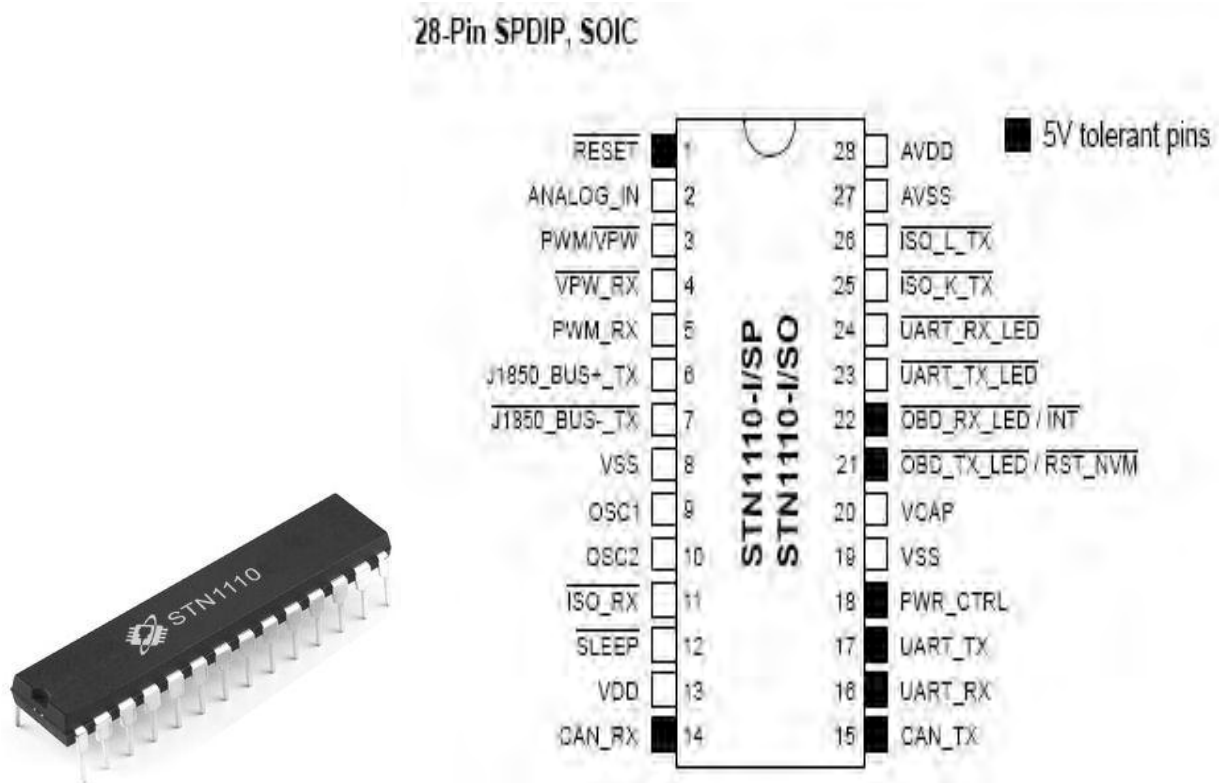

Figure 3 .1 STN1110 IC Pin Configuration

3.2.2 STN1110 V/S ELM327 ICs

Programmed convention discovery calculation of Default ELM327 does not work on fewer automobiles that utilize the ISO 9141-2 or the SAE J1850 convention. STN1110 consolidates prevalent calculation that assure the gadget associates dependably even to vehicles which don't absolutely consent to the OBD-II gauges criteria. Given figure demonstrate stick design of STN1110.

| | ELM327 v1.4 | STN1110 |
|--|----------------------|--------------------------|
| Base microcontroller | PIC18F2580 | PIC24HJ128GP502 |
| Architecture | 8-bit | 16-bit |
| Processing speed | 4 MIPS | 40 MIPS |
| Flash (ROM) | 32 KB | 128 KB |
| RAM | 1.5 KB | 8 KB |
| Pin count | 28 | 28 |
| Available packages | PDIP, SOIC | PDIP, SOIC, QFN |
| Supply voltage range | 4.5 to 5.5V | 3.0 to 3.6V ¹ |
| Supports all OBD-II protocols | yes | yes |
| ELM327 command set | yes | yes |
| Enhanced "ST" command set | no | yes |
| Firmware upgradeable | no | yes |
| Large OBD message memory buffer | no | yes |
| Low power mode | yes | yes |
| Supported UART baud rates | 9600 bps to 500 kbps | 38 bps to 10 Mbps |
| OBD message filtering | basic | advanced |

Table 3.1 ELM 327 VS STN 1110

3.3 LM399PWR (Comparator)

This bundle comprises of four free voltage comparators and configuration to work for a solitary voltage supply. Figure 3.1 demonstrate LM399PWR IC and the pins setup of LM399PWR.

3.3.1 Characteristics:

- It has underlying resilience of 2 %.
- It has temperature coefficient of 0.5 sections for every million.

3.3.2 Functions:

- Precise voltage reference for millimeters.
- Lab estimation hardware.
- Utilized as a part of Industrial screen instruments
- Utilized as High exactness information converters

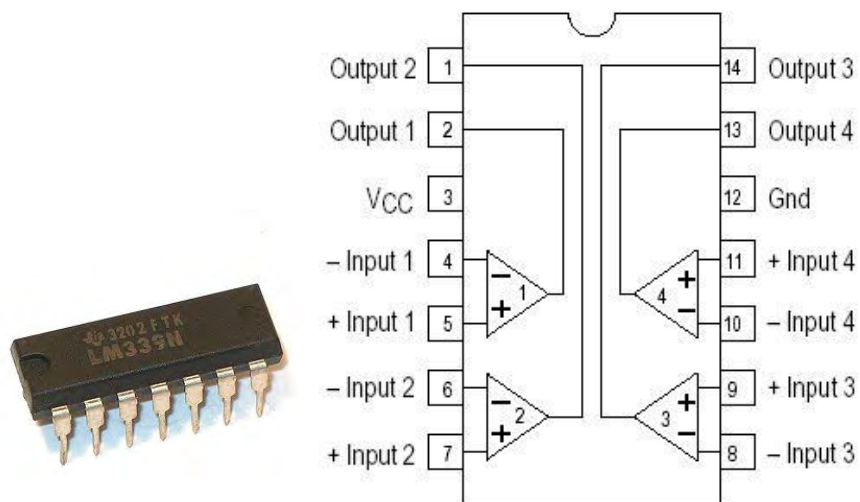

Figure 3.1 LM399PWR

3.4 "LM317LD" (Positive /Electrical energy Regulators)

LM317LD is a J1850 handset. That be a movable optimistic electrical energy controller that have capacity of overabundance in progress (I) is 100 mA through which can exert electrical energy 1.2 v up to 37v and figure 3.2 demonstrates the association outline of LM317LD

3.4.1 Characteristics:

1. Capacity of overabundance current (I) is 100 MA
2. This be able to exert 1.2 V up to 37 V
3. Yield transistor safe territory remuneration
4. Eliminate stock a lot of settled voltages.

3.4.2 Features

- 1.** Ability of abundance Current is 100 mA
- 2.** It can exertion 1.2 V up to 37 V
- 3.** Output Transistor Safe–Area Compensation
- 4.** Eliminates Stocking Many Fixed Voltages

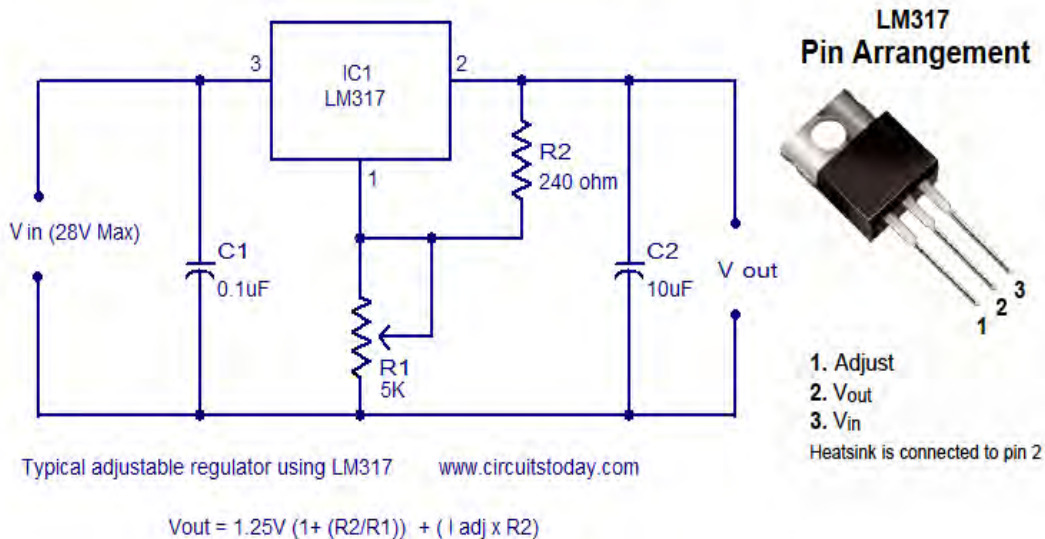

Figure 3.2 LM 317 Pin Configuration and biasing

3.5 MCP2551

This MCP2551 is a CAN handset. Border among a CAN convention administrator and material transport could might be serve by MCP2551 transmit and getting for the CA convention controller is given by MCP2551. Working pace is up to 1 Mb per second and indicates stick arrangement of MCP2551.

3.5.1 Characteristics:

- It ropes 1 MB per second activity.
- It preserve exertion 12 V up to 24 V.
- Power (ON) reset and voltage dark colored out insurance.
- CAN transport will not be aggravated un power hub.
- Short circuit reserve task.

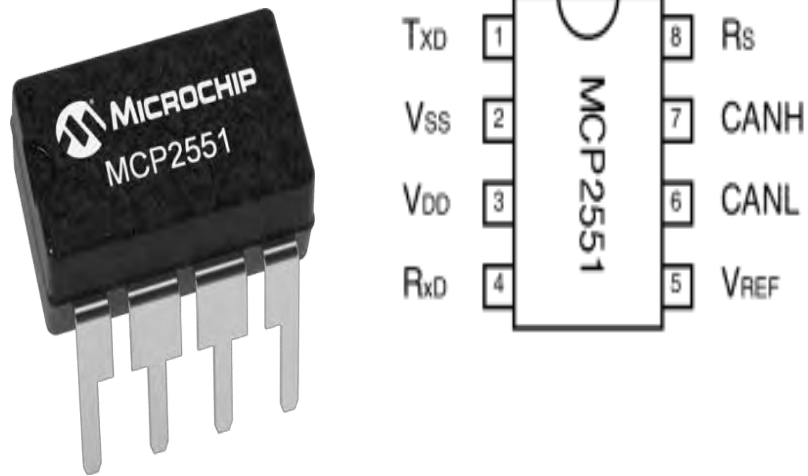

Figure 3.3 MCP2551 IC

3.6 78M05 (5V Voltage Regulator)

This 7805 is 5V voltage controller. This bolster input voltage up to 37V and look after yield voltage with a steady estimation of 5V. Proper estimations of capacitors are associated with input what's more, yield pins relying on the required voltage level.

3.6.1 Characteristics

- This can create output Current up to 0.5A
- This create output electrical energy of 5V
- Thermal overwork security.
- Give low circuit security.

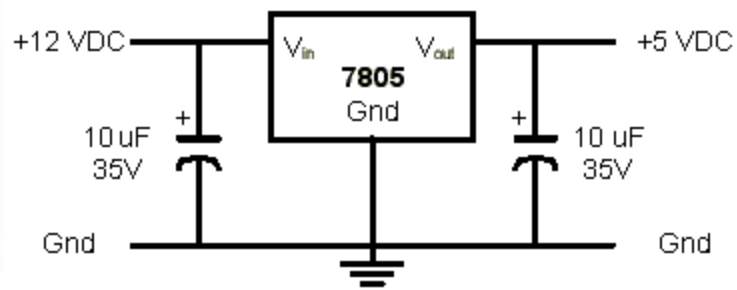
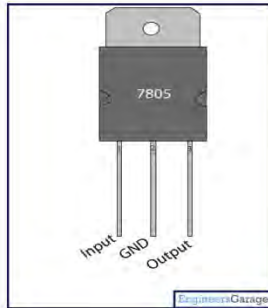

Figure 3.4 78M05 IC

3.7 AME1117 (3.3V Voltage Regulator)

This AME1117 is a 3.3V positive electrical energy controller. This bolster put incurrent up to 7V and keep up yield power at a consistent estimation of 3.3V. For this necessary yield electrical energy level is suitable estimations of capacitor will be associated with the info by yield pin.

3.7.1 Functions:

- This is High Efficiency Linear Voltage Regulators.
- This can change over 5V in to 3.3Volt.
- It's utilized as a part of Battery Charger.

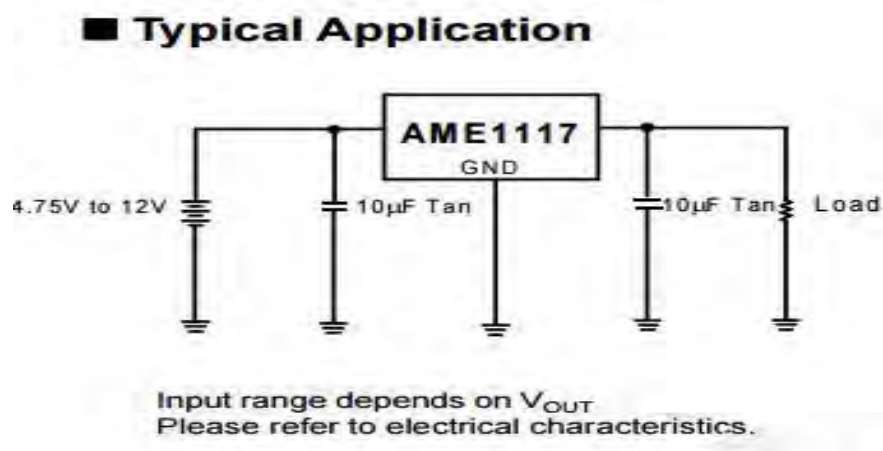

Figure 3.5 AME1117 (3.3V Voltage Regulator)

3.8 Diodes

Diodes are utilized for direction reason here. 1N4148 diode is utilized here which is examined underneath:

3.8.1 Description:

It is an exchanging diode. It likewise utilized as a part of rapid amending.

3.8.1.1 Features

- Exchanging speed is quite high.
- This has high Reliability.
- It has low current spillage.

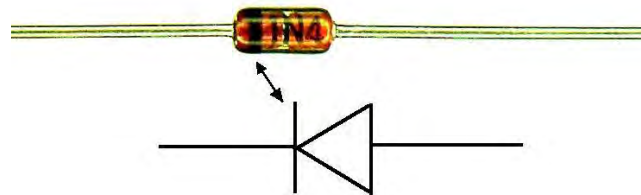

Figure 3.6 1N4148

3.9 Transistor:

3.9.1 2N3904

It is NPN General Purpose Amplifier. Its stick arrangement is appeared.

3.9.1.1 Feature

It is utilized as intensifier and as a switch.

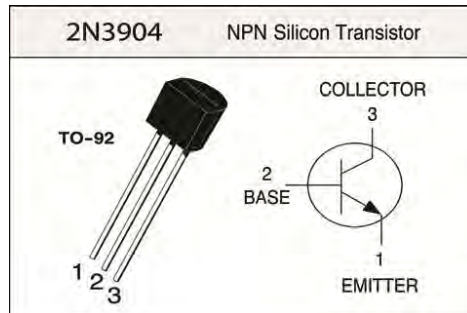

Figure 3.7 2N3904 Transistor

3.9.2 2N3906

It is PNP exchanging transistor. Its stick outline is appeared.

3.9.2.2 Applications

High-speed exchanging utilized as a part of modern applications.

3.10 DLC (Data Link Connector)

Information connection is associated below the rush next to controlling segment. It has 16 pin demonstrative link utilized meant for association through ECU. These interfaces OBD-II examine apparatus with the vehicle PC and give access to On-Board Diagnostic and live information streams.

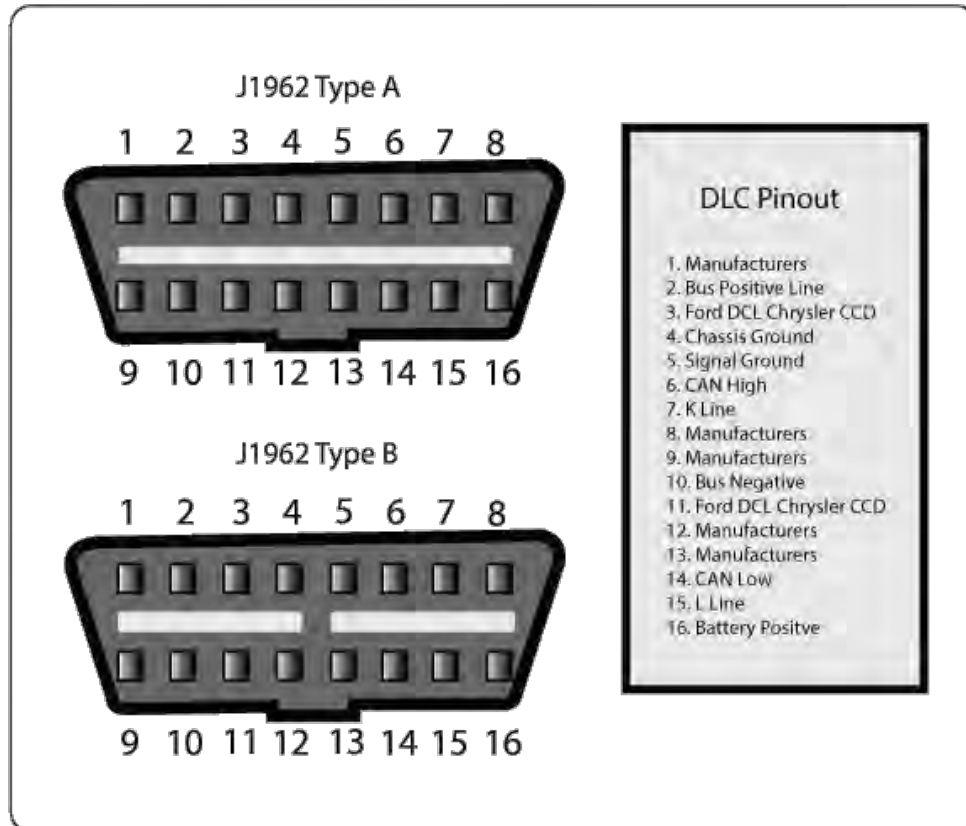

Figure 3.8 DLC (Data Link Connector) Pin Diagram

3.11 Bluetooth Serial Interface Module

It is a distinctive level of this unit. HC-06 is respectful stage unit. It's utilized to change over sequential port to Bluetooth. There are two methods of Bluetooth modules ace what more, slaver gadget is. This HC-06 module can just only be a slave.

INPUT: This stick need to stop at the same time as control on-reset of the module to implement AT mode.

VCC: This demonstrates the electrical energy and work for both 3.3V and 5V.

GND: This describes ground.

TXD (Transmission Data): This stick can be associated with RX of STN1110 PIC microcontroller as a yield of the module.

RXD: This stick can be associated with TX of the STN1110 PIC microcontroller as a contribution of the module.

State: This stick is associated with LED of module and is used to check the association of module.



Figure 3.9 Bluetooth Module

3.12 Hardware Implementation

3.12.1 Block Diagram

Before completing the circuit the square diagram was plan for straightforwardness. The square outline addresses the surge of wander. This information associate device will be added with auto (OBD-II) ,where the line driver power will be interface with it and besides the line driver circuit is interfaced with rule part (STN1110) controller. The STN1110 part will then be affixed with correspondence translational circuit here in this circumstance Bluetooth will be used to send the data remotely.

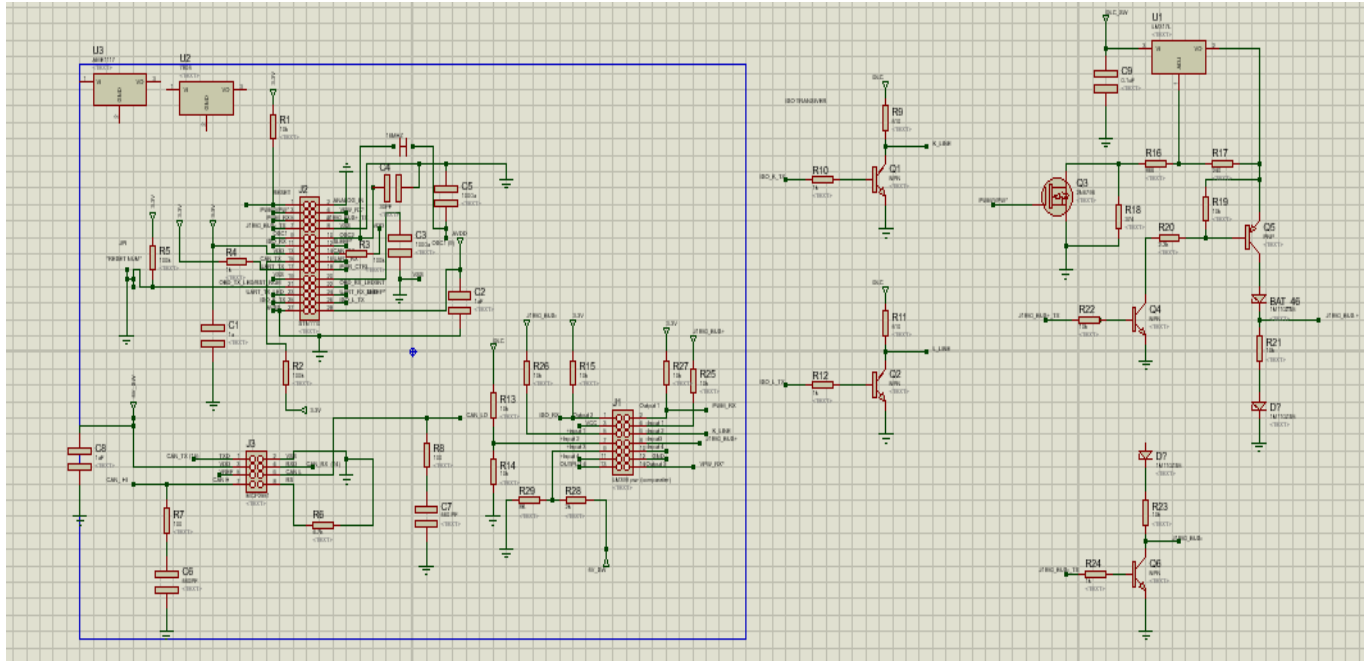

Figure 3.10 Proteus Diagram

ISO_TRANSIVER

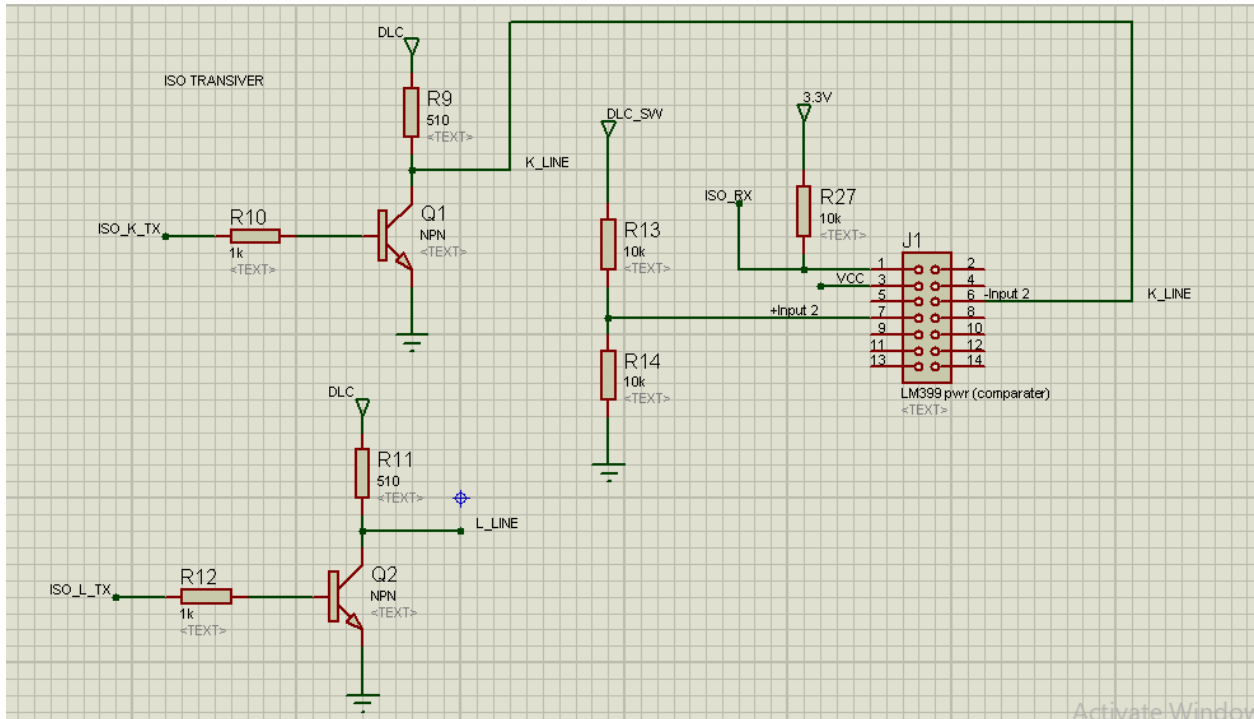

Figure 3.11 ISO_Transiver Diagram

3.12.3 Circuit Diagram

Keeping in mind the end goal to speak with the STN1110 IC, a correspondence interface should be created. A small scale controller utilized as Communication Bridge expects oscillator to give beats. Hardware, the designers of the STN1110 IC give a schematic of suggested associations for it. The schematic is duplicated in light of inaccessibility of some suggested segments. The followings figures demonstrates schematic and PCB. Configuration creates in Proteus application. The entire circuit outline of this undertaking, utilizing a Breadboard beginning from the controller that supplies unadulterated DC (direct current) voltage to the STN1110, comparator, high speed CAN as these segments must be enacted through legitimate power source so that they will work correctly. The STN1110 can be utilized as a focal part that

will play out the principle undertaking. In the wake of executing the square and circuit outline now it is effortlessly to assemble the equipment figure 3.12 (PCB).

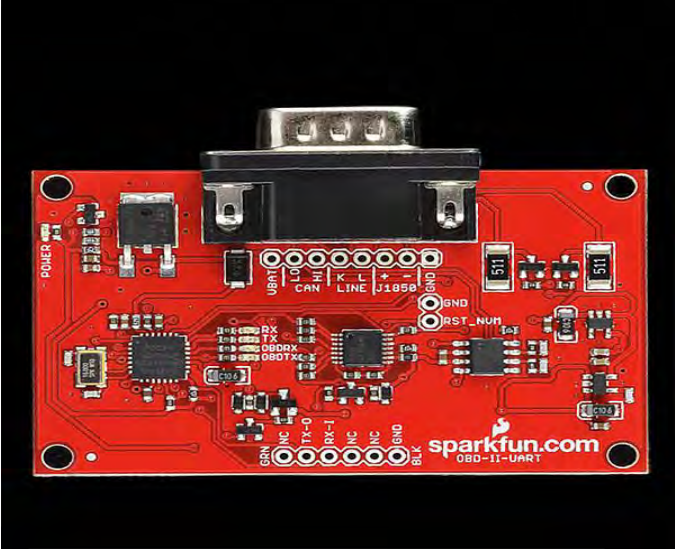

Figure 3.12 PCB Design Circuit

Bread Board Design Circuit

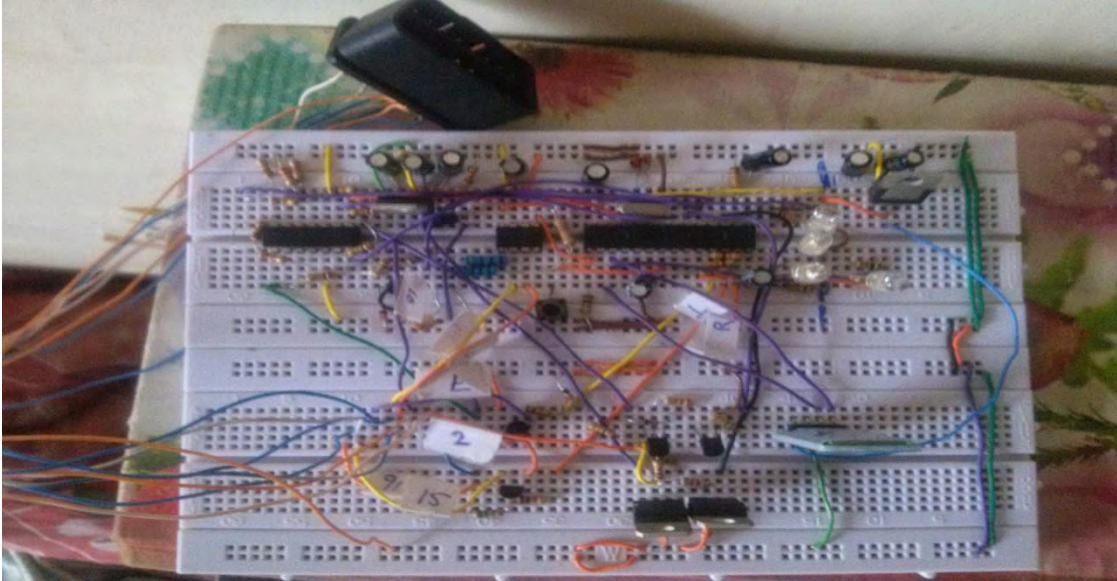

Figure 3.13 Bread Board Design Circuit

Chapter 4

Testing and Results

4.1 Testing OBDII Hardware

To work with OBDII model, it should be tried first, to ensure that the equipment hardware, serial correspondence and additionally the flagging convention worked fine. To do as such a terminal programming called Teraterm is utilized. After effective testing the equipment is at that point applied on vehicle progressively this gives the right estimation.

4.1.1 Testing Through Teraterm Terminal

Before associating the OBD_II Circuit to any vehicle, the circuit ought to be checked first to affirm the serial correspondence. The easy method to test the circuit is, by utilizing HyperTerminal and Teraterm programming. To do this, associate the OBDII circuit with Teraterm terminal through Bluetooth. In any case before to begin with testing first set the setup of Teraterm as appeared in the different figures. In the wake of associating TeraTerm interface with the OBDII by means of Bluetooth. Test each convention in succession keeping away from vehicle association. In the event when all goes well and you witness that just these content “NO DATA” or “UNFIT TO CONNECT” at that point all goes right and the equipment work effectively. On the off chance that others content shows up amid testing rather than the above then there will be blames in equipment circuit. After fruitful testing associate the equipment to a genuine vehicle. The followings are yield results amid testing. ATZ Command for checking the group of small scale controller and its variant STN1110 v1.30 0100 Command.

ATE1 Command for checking status of the smaller scale controller. 9.1V Command for checking the voltage of the circuit.

4.1.2 Real Time Testing

Torque is a vehicle/auto execution/diagnostics instrument and scanner that uses an OBD II Bluetooth connector to associate with OBD2 motor control unit (ECU). It can utilize the GPS to give tracker logs OBD motor logging so you can perceive what you were doing at any point progressively. It can likewise show and reset a DTC blame codes and show you correct area of issues. To begin with OBDII and Torque, First associate the OBDII with vehicle on one side and with Torque on opposite side. Effective association of torque with OBDII. Subsequent to building up the association of torque with specialized gadget, the data is then recovering from the motor vehicle (ECU). Connector rank data also describes the vehicle OBD standard, OBD convention utilized by automobile, alignment id and accessible sensor and so forth. The OBD_II port is equipped for perusing the data from any automobile:

- Turbo boost pressure (PSI).
- Fuel financial system (Real-Time/AVG/Trip).
- Time and situation.
- Speed i.e. (MPH, KPH)
- Engine Revolutions per Minute.
- Coolant temperature.
- Throttle position (percentage).
- Injection Pulse width or (IPW).
- Intake Temperature of air.

- Mass air flow (g/sec).
- Throttle position.
- Barometer.
- Battery Voltage (V).
- Engine oil temperature.
- Injection control pressure or (ICP).
- Transmission temperature.
- Load.

Vehicle used for testing and execution investigation in figure 3.14 was Suzuki Cultus Model 2014.



Figure 3.14 Real Time Testing

4.1.3 Project folder Data and Its Output

The accompanying document organize is a CSV record which was gathered amid testing different parameters. The Torque gathers information through OBDII frame ECU and stores it as CSV document on customary interims. To investigation the information, one can draw any kind of chart in view of their necessities and prerequisite. The accompanying distinctive charts are drawn with different parameter such voltage, RPM, Air fuel Ratio and so forth taken from the above information. These charts are drawn by utilizing Torque log analyzer. Torque log analyzer is a device for checking the driver style and featuring conduct that can squander fuel and other stuff of vehicle. As observed from the above outcomes, one can without much of a stretch examination vehicle heath and driver conduct of driving. This procedure can limit cost, time and enhance execution of vehicle. In short one can see each status of his vehicle. It can be executed in any branch of industry, instructive foundations, media transmission ventures and so forth.



Figure 3.15 Output

Chapter 5

Application & Conclusion

Potential Application of our proposed and created work is: one can remotely screen vehicle wellbeing, check shortcomings, outflow identification issues, stay away from the higher fuel utilizations and so forth. Utilizing this parameters individual or businesses or gatherings can streamline the cost of vehicles and issues can be anticipated and inform the supervisors in time.

5.1 User Applications

Individual and Industrial Users can profit by it from numerous points of view. E.g. he can find their vehicle screen the vehicle execution and distinguish blames in any piece of vehicle. To distinguish the blame on time one can drive securely and forestall mischances. Client can profit by it by checking his vehicle itself, hence diminish activity and mechanical expenses.

5.1.2 Enterprise applications

Some Enterprise application may incorporate Fleet following, observing fuel productivity. Through this gadget Enterprise can know the driving conduct of their drivers. Likewise they can remotely demonstrative their vehicles in regions where vehicle repair benefit isn't accessible.

5.2 Informative supplement D

5.2.1 OBDII

In the 1970's and later in 1980's makers' in progress of utilizing electronic intends to control motor usefulness and identify motor issues. It was the basically plan to meet EPA outflow principles. Throughout the years OBDII framework has turned out to be more created.

OBDII another standard was introduced in 1990 which give all motor control and likewise screens parts of the frame, body and extra gadgets, and also the indicative control system of the vehicle. For keeping away from exhaust cloud issues in the Los Angeles Basin, the California state began requesting a discharge control frameworks on 66's autos models. Exhaust cloud issue during the L.A bowl, the foreign country began request in outflow control frameworks on 1966 model autos. A while later the national Government in 1968 broadens these controls countrywide. Congress affirmed the Clean Air Act in 1970 and built up (EPA).

In this manner a grouping of graduate discharge gauges and prerequisites for improvement and upkeep of vehicle wellbeing had begun for expanded timeframe. To happen upon these principles, makes transformed into automatically restricted firewood supply and start frameworks. Distinctive sensors accessible in the vehicle estimated motor execution and balanced the frameworks to give least contamination. In the first place every producer had their own system for extricating information. In 1988, the Society of Automotive Engineers (SAE) redefines connector attachment and a set of symptomatic test signals. This define connector plug comprises of sixteen (16) stick and in which five (5) are information pins. OBD_II is an expanded arrangement of norms and practices created by SAE what's more, received by the EPA and (CARB) California Air Resources Board for usage by 1 January 1996.

5.2.2 OBD-II as a Standard Connector and Protocols:-

OBDII was at first exhibited in US in 1994, and then in 1996 it wound up essential in more current US vehicles. Comparable enactment is additionally received by different nations like European Union, Australia, Canada and Brazil. We can get to the vehicle ECU through the sixteen stick standard connector called information interface controller (DLC). A sixteen (16) stick male (J1962) connector plug is associated with female connector prepared in vehicle under guiding or a dashboard. Each stick has allocated its own particular flagging convention. This unmistakable stick contact combinations make sense of which tradition is being utilized at the present time as everyone gathering association utilizes its specific convention. The sorts of data you recuperate will depend on upon the yield interface you're using.

5.2.3 Deciding PROTOCOL FROM OBD-II PINOUT

If all else fails, we can recognize which convention our vehicle is utilizing by looking at the stick format of the OBDII connector. The accompanying demonstrates the discussing pins with regard to particular convention.

5.2.4 OBD-II Signal Protocol Description

Mainly five conventions are being used with OBD-II interface, and frequently it's conceivable to make an informed figure about the convention being used in light of which pins are available on the J1962 connector:

- SAE J1850 PWM (41.6k baud, standard of the Ford Motor Company)
 - (1) Pin 2: Bus-
 - (2) Pin 10: Bus+

- (3) The High voltage is +5V.
- (4) Message length has been limited to 12 bytes, including CRC.
- (5) Employs a multi-access assertion scheme called 'Bearer Sense Various Access with Non-Destructive Arbitration' (CSMA/NDA).
- SAE J1850 VPW (Variable Pulse Width) (10.4/41.6 kbaud, standard of General Motors)
 - (1) Pin 2: Bus+
 - (2) Bus lingers low.
 - (3) The high voltage is +7V.
 - (4) And decision point is +3.5V.
 - (5) Mainly message length is limited to 12 bytes, including CRC.
 - (6) Employs CSMA/NDA.
- ISO 9141-2. This convention has an information rate of 10.4 kbaud, and is like RS232. ISO 9141-2 is fundamentally utilized as a part of Chrysler, European, and Asian vehicles
 - (1) Pin 7: K-line
 - (2) Pin 15: L-line (discretionary)
 - (3) UART flagging (however not RS-232 voltage levels)
 - (4) K-line lingers high
 - (5) High voltage is battery
 - (6) Message length is limited to 12 bytes, including CRC
- ISO 14230 KWP2000 (Keyword Protocol 2000)
 - (1) Pin 7: K-line
 - (2) Pin 15: L-line (discretionary)

(3) Physical layer indistinguishable to ISO 9141-2

(4) Data rate 1.2 to 10.4 k baud

(5) Message may contain up to 255 bytes in the information field

- ISO 15765 CAN (250kbit/sec or 500kbit/sec)

(1) Pin 6: CAN High

(2) Pin 14: CAN Low

Note: Pin 5 (Battery ground) and stick 16 (Battery positive) are available on the whole arrangements. As ISO 9141 and ISO 14230 utilize a similar stick format, in this manner we can't separate between the two by essentially looking at the DLC connector.

5.2.5 OBD-II Diagnostic Data

At the point when there is an investigating issue inside a vehicle, the OBDII recover different information from ECU and give profitable wellspring of data. The standard SAE J1979 depicts a strategy for asking for various demonstrative information and a rundown of standard parameters which might be accessible from ECU. The few factors which are accessible are known as "parameter ID numbers" OR PIDs. They are clarified in J1979. The EMC (motor control module), PMC (control unit) continually observing standard factor ID (PID) codes. In the event that the EMC and PMC distinguish any possible issue with motor, the notice light call MIL (glitch pointer lights) is lit to give caution to driver about the issue. After 1996 each vehicle must be equipped for sending and getting these codes over it OBDII connector.

We require mix of programming desktop application/android application and equipment (OBD_II examine device) to take data from ECU. The equipment goes about as a link between the demonstrative connector and gadget that runs programming for perusing codes and

information. OBDII gives approach to perusing codes and a wide range of data. E.g. live information, test result and ECU data. It record and show any inconvenience code that the vehicle is sending. Clients would then be able to utilize the code to perceive what's off with the vehicle.

5.3 What is DTC

They are alphanumeric codes that any vehicle's PC returns when it observe a disappointment. Such codes are exchanged by a vehicle's ready diagnostics (OBD) framework and will be perused using demonstrative scanner that makes attachments into the OBD connector. With the graphical representation we could without much of a stretch get it the configuration and estimation of DTC

5.4 Conclusions

In this work, we present a design to efficiently connect and acquire data from commercial automobiles that are equipped with OBD-II computers. The design of a circuit achieves connectivity for vehicles equipped with an on-board diagnostics computer—second generation (OBD-II) computer. The engine control unit (ECU) is accessed and the data is processed for diagnostics and analysis by using STN1110 mediator integrated circuit. The design supports all the OBD protocols, which include ISO protocols and CAN Bus protocols. The Bluetooth interface is used to provide connectivity to the OBD-II computer and the users monitor and operate the system through a mobile phone application. An efficient interface is provided to troubleshoot engine errors, emission errors and other automobile system errors.

References:

- [1] OBD-II PIDs, http://en.wikipedia.org/wiki/OBD-II_PIDs

- [2] Scan tool, <http://www.scantool.net/>

- [3] ELM Electronics, <http://www.elmelectronics.com/>

- [4] <http://ahdesign.us/blog/stn1170-bluetooth-obdii-adapter/bluetooth-obdii-adapter/>

- [5] <http://torque-bhp.com/software/torque-android-obd2-adapters/>.

- [6] http://www.obdsol.com/downloads/stn1110_vs_elm327.pdf

- [7] <https://howtomechatronics.com/tutorials/arduino/arduino-and-hc-05-bluetooth-module-tutorial/>